

# OPERATION AND INSTALLATION

Integral tank

» HSBC 300 Integral

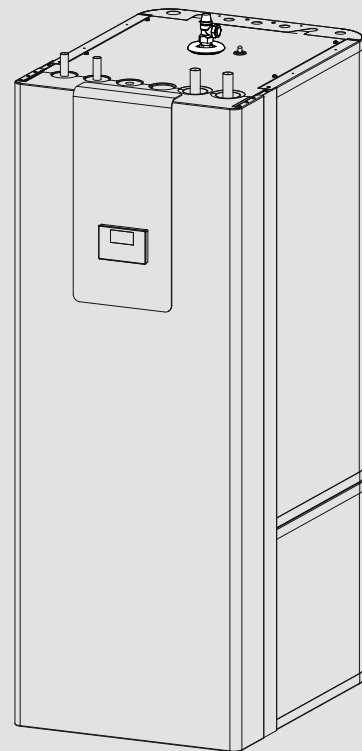

Certified to ANSI/UL Std. 174  
Conforms to CAN/CSA Std. C22.2 No. 110

Certificación con ANSI/UL Std. 174  
Conforme a CAN/CSA Std. C22.2 No. 110

Certifié à la norme ANSI/UL Std. 174  
Conforme à la norme CAN/CSA Std. C22.2 No. 110



Tested and certified by WQA to NSF/ANSI/CAN 372  
for lead free compliance.

Probado y certificado por WQA NSF/ANSI/CAN 372 para  
el cumplimiento de las regulaciones sin plomo.

Testé et certifié par WQA à la NSF/ANSI/CAN 372 pour  
une utilisation sans plomb.

**STIEBEL ELTRON**

---

# CONTENTS

---

## SPECIAL INFORMATION

17.5 Data table \_\_\_\_\_ 29

## OPERATION

17.6 Accessories \_\_\_\_\_ 30

<b>1. General information</b>	<b>3</b>
1.1 Relevant documents	3
1.2 Safety instructions	3
1.3 Other symbols in this documentation	4
1.4 Information on the appliance	4
1.5 Units of measurement	4
<b>2. Safety</b>	<b>4</b>
2.1 Intended use	4
2.2 General safety instructions	4
2.3 Test symbols	4
<b>3. Appliance compatibility</b>	<b>5</b>
<b>4. Appliance description</b>	<b>5</b>
<b>5. Cleaning, care and maintenance</b>	<b>5</b>
<b>6. Troubleshooting</b>	<b>5</b>

## INSTALLATION

<b>7. Safety</b>	<b>6</b>
7.1 General safety instructions	6
7.2 Instructions, standards and regulations	6
<b>8. Appliance description</b>	<b>6</b>
8.1 Standard delivery	6
8.2 Accessories	6
<b>9. Preparation</b>	<b>6</b>
9.1 Installation site	6
9.2 Transport and handling	7
<b>10. Installation</b>	<b>11</b>
10.1 Positioning the appliance	11
10.2 Heating water connection	11
10.3 DHW connection and safety assembly	14
10.4 Filling the system	15
10.5 Venting the appliance	16
<b>11. Electrical connection</b>	<b>16</b>
11.1 Control voltage	16
11.2 Safety extra low voltage	17
11.3 Heat pump manager terminal assignment	17
11.4 Accessories	18
11.5 Sensor installation	19
11.6 Remote control	19
<b>12. Commissioning</b>	<b>19</b>
12.1 Checks before commissioning the heat pump manager	19
12.2 Commissioning the heat pump manager	19
<b>13. Settings</b>	<b>20</b>
13.1 Wilo-Para .../Sc circulation pumps	20
<b>14. Appliance handover</b>	<b>21</b>
<b>15. Shutting down the system</b>	<b>21</b>
<b>16. Maintenance</b>	<b>21</b>
<b>17. Specification</b>	<b>22</b>
17.1 Dimensions and connections	22
17.2 Hydraulic diagram	24
17.3 Wiring diagram	26
17.4 Sample installation	29

# SPECIAL INFORMATION OPERATION

- The appliance may be used by children over 8 years of age and persons with reduced physical, sensory or mental capabilities or a lack of experience and expertise, provided that they are supervised or they have been instructed on how to use the appliance safely and have understood the potential risks. Children must never play with the appliance. Cleaning and user maintenance must not be carried out by children without supervision.
- The connection to the power supply must be in the form of a permanent connection. Ensure the appliance can be separated from the power supply by an isolator that disconnects all poles with at least 3 mm contact separation.
- Observe all applicable national and regional regulations and instructions.
- Observe minimum distances (see chapter "Installation / Preparations / Installation site").
- Only a qualified contractor should carry out installation, commissioning, maintenance and repair of the appliance.

## DHW tank

- Drain the appliance as described in chapter "Installation / Maintenance / Draining the DHW tank".
- Observe the maximum permissible pressure (see chapter "Installation / Specification / Data table").
- The DHW tank is under supply pressure. During the heat-up process, expansion water will drip from the safety valve.
- The safety valve drain aperture must remain open to atmosphere.

## 1. General information

The chapters "Special information" and "Operation" are intended for appliance users and qualified contractors.

The chapter "Installation" is intended for qualified contractors.



### Note

Read these instructions carefully before using the appliance and retain them for future reference. Pass on these instructions to a new user if required.

### 1.1 Relevant documents

- Instructions for the WPM heat pump manager
- Operating and installation instructions for the connected heat pump
- Operating and installation instructions for all other system components

### 1.2 Safety instructions

#### 1.2.1 Structure of safety instructions



#### KEYWORD Type of risk

Here, possible consequences are listed that may result from failure to observe the safety instructions.

► Steps to prevent the risk are listed.

#### 1.2.2 Symbols, type of risk

Symbol	Type of risk
	Injury
	Electrocution
	Burns (burns, scalding)

#### 1.2.3 Keywords

KEYWORD	Meaning
DANGER	Failure to observe this information will result in serious injury or death.
WARNING	Failure to observe this information may result in serious injury or death.
CAUTION	Failure to observe this information may result in non-serious or minor injury.

### 1.3 Other symbols in this documentation



#### Note

General information is identified by the adjacent symbol.  
► Read these texts carefully.

Symbol	Meaning
	Material losses (appliance damage, consequential losses and environmental pollution)
	Appliance disposal

- This symbol indicates that you have to do something. The action you need to take is described step by step.

### 1.4 Information on the appliance

#### Connections

Symbol	Meaning	
	Inlet / intake	Red arrow: hot Blue arrow: Cold Green arrow: Neutral
	Drain / outlet	Red arrow: hot Blue arrow: Cold Green arrow: Neutral
	Domestic hot water	
	DHW circulation	
	Heat pump	
	Heating	

### 1.5 Units of measurement



#### Note

All measurements are given in inches (mm) unless stated otherwise.

## 2. Safety

### 2.1 Intended use

This appliance is intended to be used for seasonal heating and cooling of interiors and for DHW heating.

The appliance is intended for domestic use. It can be used safely by untrained persons. The appliance can also be used in non-domestic environments, e.g. in small businesses, as long as it is used in the same way.

Any other use beyond that described shall be deemed inappropriate. Observation of these instructions and of the instructions for any accessories used is also part of the correct use of this appliance.

### 2.2 General safety instructions



#### WARNING Burns

There is a risk of scalding at outlet temperatures in excess of 109 °F (43 °C).



#### WARNING Injury

The appliance may be used by children over 8 years of age and persons with reduced physical, sensory or mental capabilities or a lack of experience and expertise, provided that they are supervised or they have been instructed on how to use the appliance safely and have understood the potential risks. Children must never play with the appliance. Cleaning and user maintenance must not be carried out by children without supervision.



#### WARNING Injury

For safety reasons, only operate the appliance with the front casing closed.



#### Material losses

The system's active frost protection is not guaranteed if the power supply is interrupted.

- Never interrupt the power supply even outside the heating season.



#### Note

The DHW tank is under supply pressure. During the heat-up process, expansion water will drip from the safety valve.

- If water continues to drip when heating is completed, please inform your qualified contractor.

### 2.3 Test symbols

See type plate on the appliance.

### 3. Appliance compatibility

The appliance can be operated in conjunction with the following air source heat pumps:

- WPL 15 A2W Premium
- WPL 25 A2W Premium

### 4. Appliance description

The buffer tank and DHW tank with indirect coil are arranged one above the other and can be separated for easier handling.

The appliance has a plastic jacket with foam insulation and is equipped with a removable front casing. The appliance is connected hydraulically and electrically to the heat pump. All hydraulic connections are made at the top (heating & cooling) and rear (DHW).

In addition to the DHW tank and the buffer tank, further system components are integrated:

- Heat pump manager
- Highly efficient circulation pump for a heating circuit without a mixer
- 3/2-way diverter valve
- Primary tank pump

#### DHW tank

The tank is steel and coated on the inside with a special direct enamel and is equipped with a signal anode. The anode with consumption indicator protects the tank interior from corrosion.

The heating water heated by the heat pump is pumped through an indirect coil inside the DHW tank. The heat channeled through the indirect coil is then transferred to the domestic hot water. The integral heat pump manager (WPM) regulates the DHW heating to the required temperature.

#### Buffer tank

This steel tank provides hydraulic separation between the flow rates of heat pump and heating circuit. The heating water heated by the heat pump is transferred into the buffer tank by the tank charging pump. When a demand is issued, the integral heating circuit pump delivers the heating water to the heating circuit.

#### Heat pump manager (WPM)

The system is controlled by means of the integral heat pump manager.



**Note**

The heat pump manager has an automatic summer/winter changeover so you can leave the system switched on in summer.

- ▶ Please observe the instructions for the heat pump manager.

### 5. Cleaning, care and maintenance

- ▶ Have the electrical safety of the appliance and the function of the safety assembly regularly checked by a qualified contractor.

- ▶ Never use abrasive or corrosive cleaning agents. A damp cloth is sufficient for cleaning the unit.

#### Signal anode with consumption indicator



**Material losses**

If the consumption indicator changes color from white to red, have the signal anode checked by a qualified contractor and if necessary replaced.

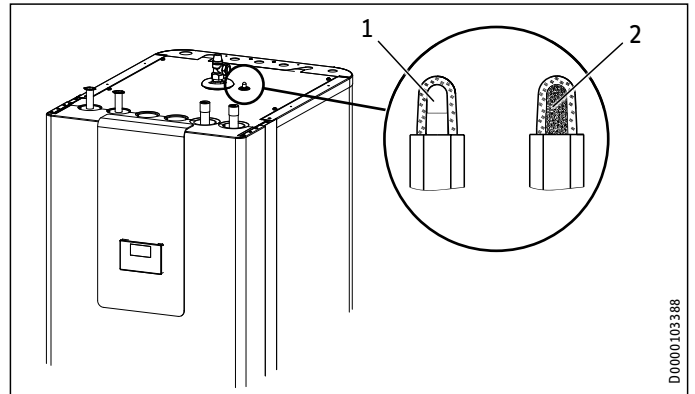

- 1 White = Anode OK
- 2 Red = Requires checking by qualified contractor

### 6. Troubleshooting

Problem	Cause	Solution
The water does not heat up. The heating does not work.	There is no power.	Check to ensure circuit breaker in breaker panel hasn't tripped. Reset if necessary.
Fluctuating system flow rate and/or inconsistent heating behavior.	Air trapped in system due to insufficient system venting.	Power purge air from system. Utilize air vent valve.

If you cannot solve the problem, contact your qualified contractor. To facilitate and speed up your inquiry, please provide the serial number from the type plate (000000-0000-000000).

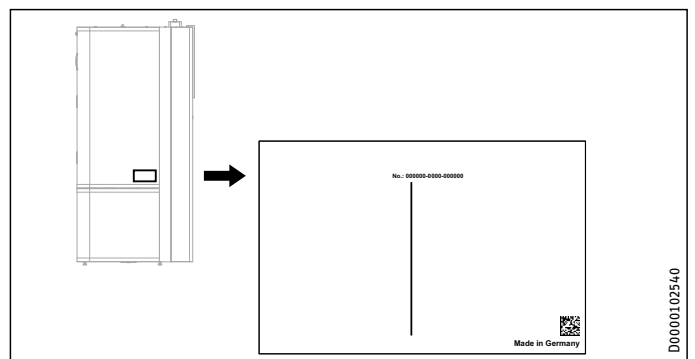

# INSTALLATION

## 7. Safety

Only a qualified contractor should carry out installation, commissioning, maintenance and repair of the appliance.

### 7.1 General safety instructions

We guarantee trouble-free function and operational reliability only if original accessories and spare parts intended for the unit are used.

### 7.2 Instructions, standards and regulations



#### Note

Observe all applicable national and regional regulations and instructions.

## 8. Appliance description

### 8.1 Standard delivery

The following are delivered with the appliance:

- 4x Adjustable foot
- 1x Outside temperature sensor AF PT
- 1x expansion vessel (incl. fastening material)
- 1x installation kit (pressure reducing valve, check valves, expansion relief valve, tundish)

### 8.2 Accessories

#### 8.2.1 Required accessories

Safety assemblies and pressure reducing valves are available to suit the prevailing supply pressure. These type-tested safety assemblies protect the appliance against impermissible excess pressure.

Required for area cooling:

- Pt1000 temperature sensor
- FET remote control

#### 8.2.2 Additional accessories

- Pump assembly for a heating circuit with mixer HSBC 3-HKM Integral
- Pipe assembly RBS-SBC Integral
- Pressure hoses
- Temperature sensor for cooling
- FET remote control for heating & cooling operation
- STB-FB high limit safety cut-out for underfloor heating systems

### Pipe assembly RBS-SBC

The domestic water hydraulic connections can be routed upwards at the rear of the DHW tank using the RBS-SBC Integral pipe assembly available as an accessory.

## 9. Preparation

### 9.1 Installation site



#### Material losses

Never install the appliance in wet rooms.

Install the appliance near the draw-off point in a dry room free from the risk of frost. To reduce line losses, keep the distance short between the appliance and the heat pump.

Ensure the floor has sufficient load bearing capacity and evenness (for weight, see chapter "Specification / Data table").

The room must not be subject to a risk of explosions arising from dust, gases or vapors.

If you are installing the appliance in a boiler room together with other heating equipment, ensure that the operation of the other heating equipment will not be impaired.

### Minimum clearances

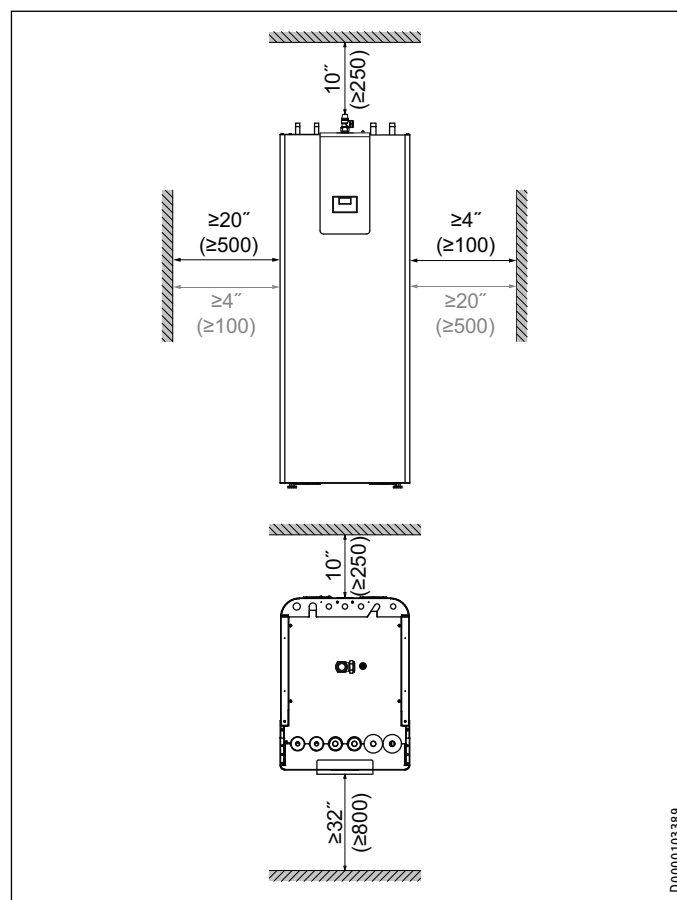

The minimum side clearances can be swapped between left and right.

# INSTALLATION

## Preparation

### 9.2 Transport and handling



#### Material losses

Store and transport the appliance at temperatures between -4 °F and 140 °F (-20 °C and 60 °C).

#### Handling

- ▶ Undo the 4 screws from the pallet.

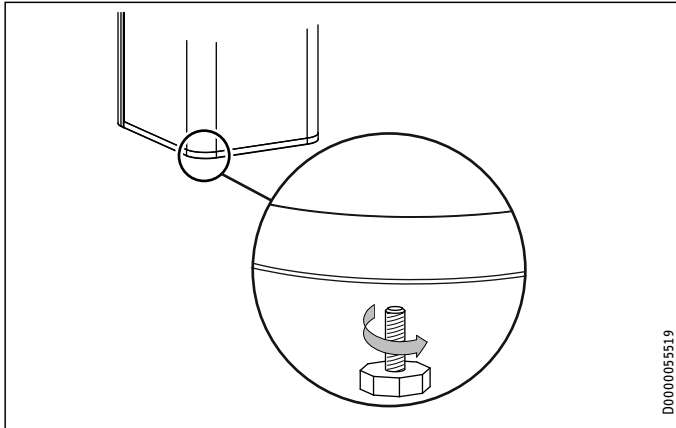

- ▶ Tilt the appliance and screw the 4 adjustable feet into the appliance.
- ▶ Lift the appliance off the pallet. For a better hold during transport, use the recessed grips on the underside and rear of the appliance.

If narrow doors or hallways hinder handling, you can separate the upper and lower sections of the appliance as described in the following chapters.

### 9.2.1 Removing/fitting the front casing

#### Removing the front casing

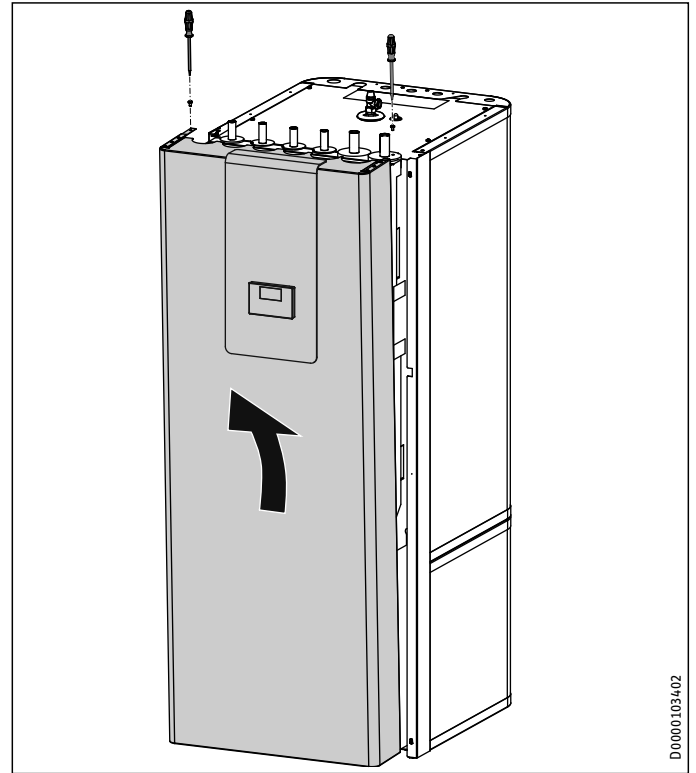

- ▶ Remove the 2 locking screws on the top of the front casing.
- ▶ Unhook the front casing towards the top.
- ▶ AA01-X1.18: If required, disconnect the connector plug of the programming unit from the connection in the appliance. The functionality of the appliance will not be affected. However, it will not be possible to operate the appliance via the programming unit.
- ▶ Remove the earth cable from the front casing.

#### Fitting the front casing

- ▶ Fit the front casing in reverse order.

# INSTALLATION

## Preparation

### 9.2.2 Overview of insulation segments

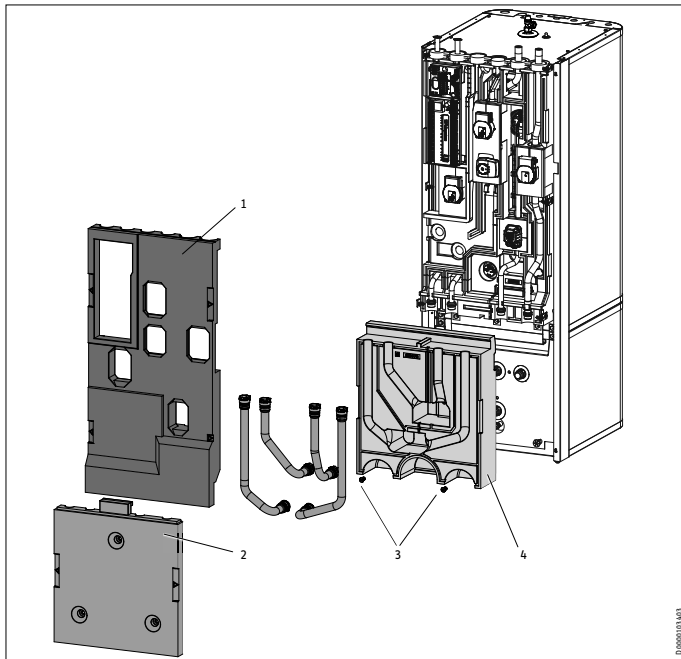

- 1 Insulation segment 1
- 2 Insulation segment 2
- 3 Insulation material screw
- 4 Insulation segment 3

### 9.2.3 Separating / joining the appliance sections

#### Separating the appliance sections



#### Material losses

Unscrewing the fastening screws destroys the threads in the insulation segment.

- ▶ To open the 3 fixing tabs, loosen the fastening screws slightly but do not unscrew them completely.

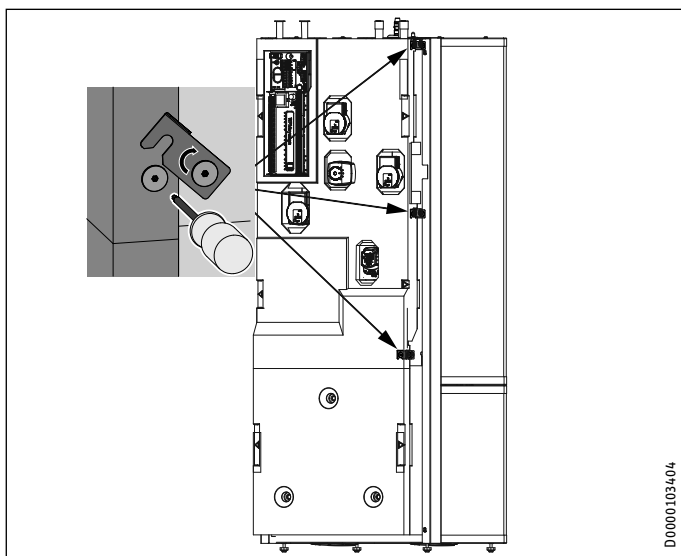

#### Note

To make removal simpler, the insulation segments have labeled recessed grips on the left and right.

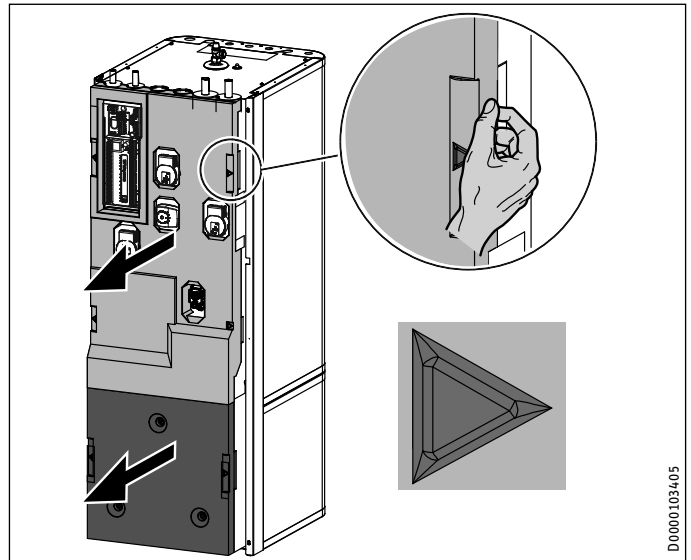

- ▶ Remove insulation segment 1.
- ▶ Remove insulation segment 2.

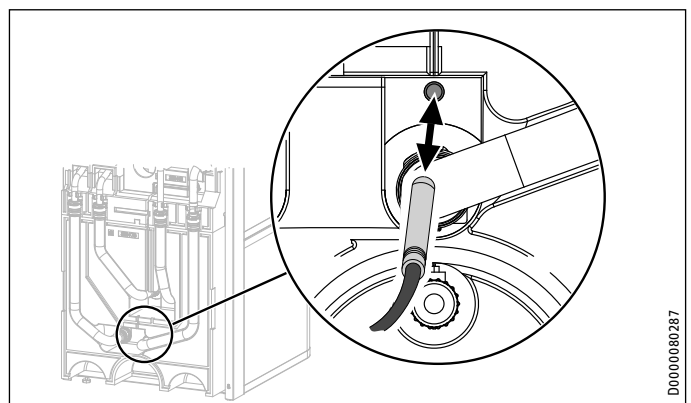

- ▶ Pull the "heating sensor" out of the buffer tank.

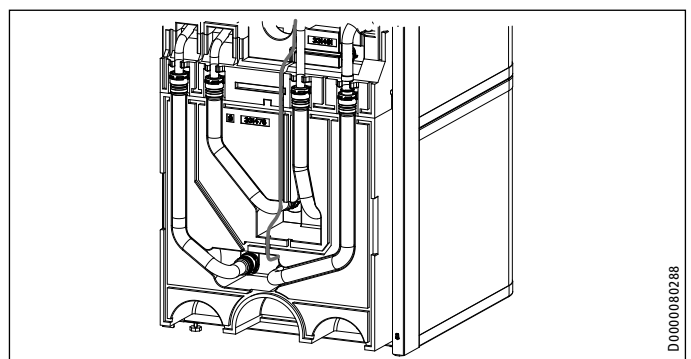

- ▶ Release the sensor lead from the guide groove in the insulation segment.



# INSTALLATION

## Preparation

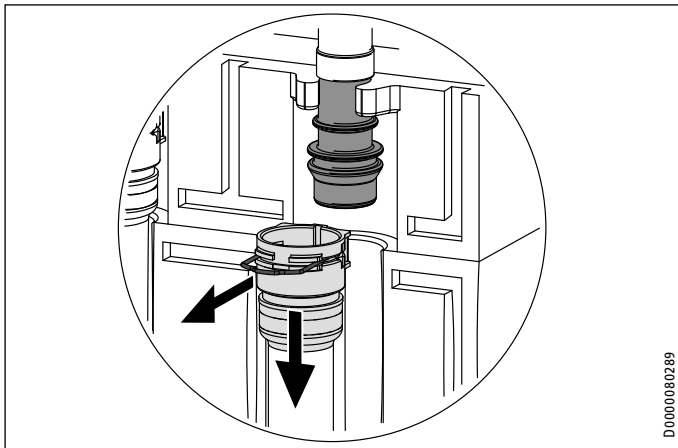

D0000080289

- ▶ Disconnect the push-fit connectors of the 4 hydraulic connections. To do this, pull the spring clips fully out with a screwdriver.
- ▶ Pull the hydraulic connectors as indicated.

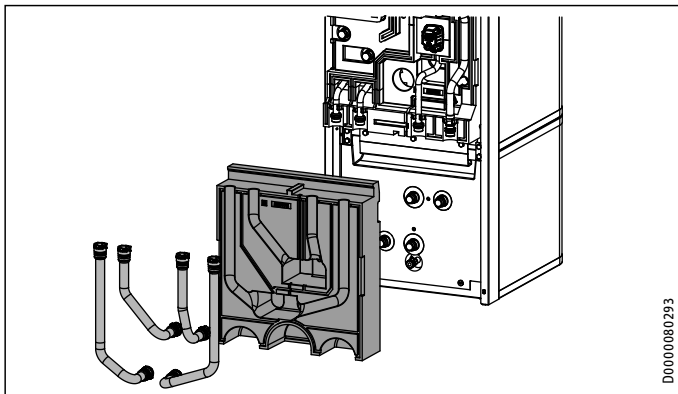

D0000080293

- ▶ Remove the 4 hydraulic hoses.
- ▶ Remove the 2 insulation material screws.
- ▶ Remove insulation segment 3.

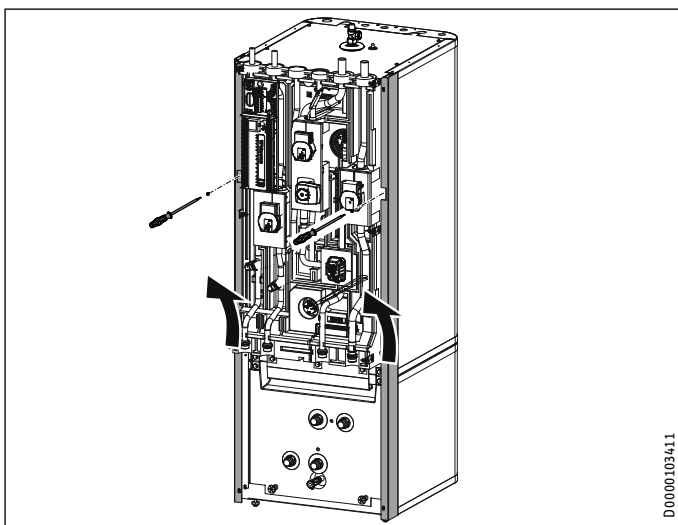

D0000103411

- ▶ Undo the 2 locking screws on the side profile strips.
- ▶ Lift up and unhook the side profile strips.

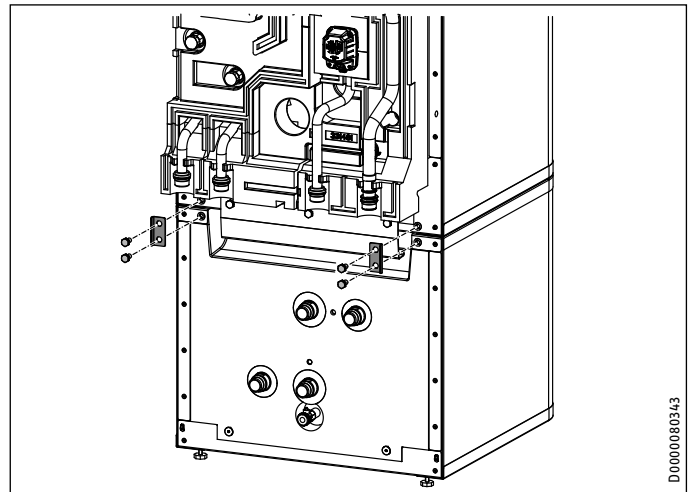

D0000080343

- ▶ Release the 4 screws on the tabs at the front of the appliance.

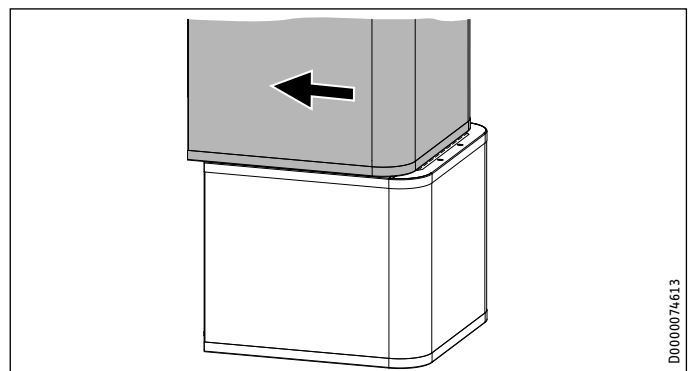

D0000074613

- ▶ Pull the upper section of the appliance towards the front.

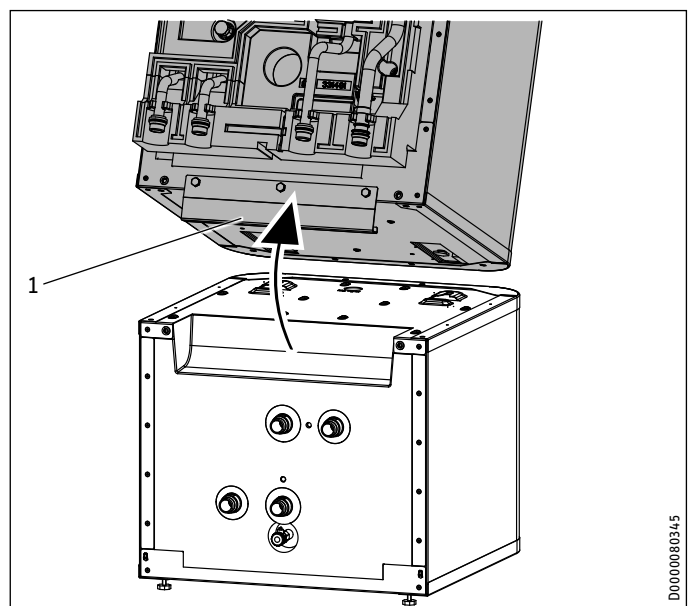

D0000080345

- 1 Handle
- ▶ Tip the upper section of the appliance backwards. Use the handle for improved grip.

# INSTALLATION

## Preparation

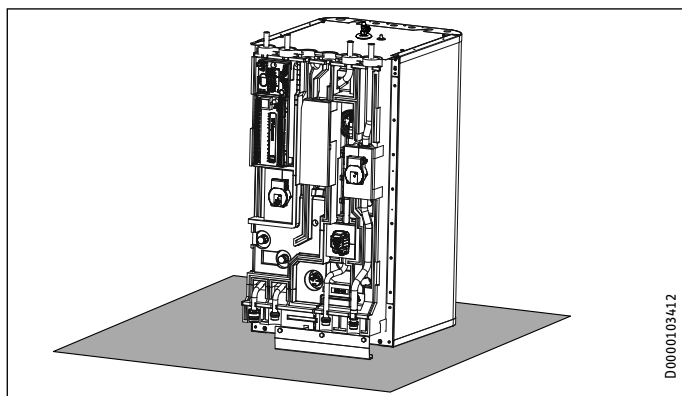

D0000103412

- ▶ Place the upper section of the appliance on a base to prevent damage.

### Joining appliance sections



#### Material losses

To prevent condensation forming, the insulation segments must fit closely against the lower section with no gaps.

- ▶ When inserting the insulation segments, ensure that the joint grooves are kept clear.
- ▶ Tap the insulation segments down with your hand.

Rejoin the appliance sections in reverse order.

The positioning aids and the dotted line marking provide assistance when positioning and inserting the upper appliance section into the guide groove on the lower section:

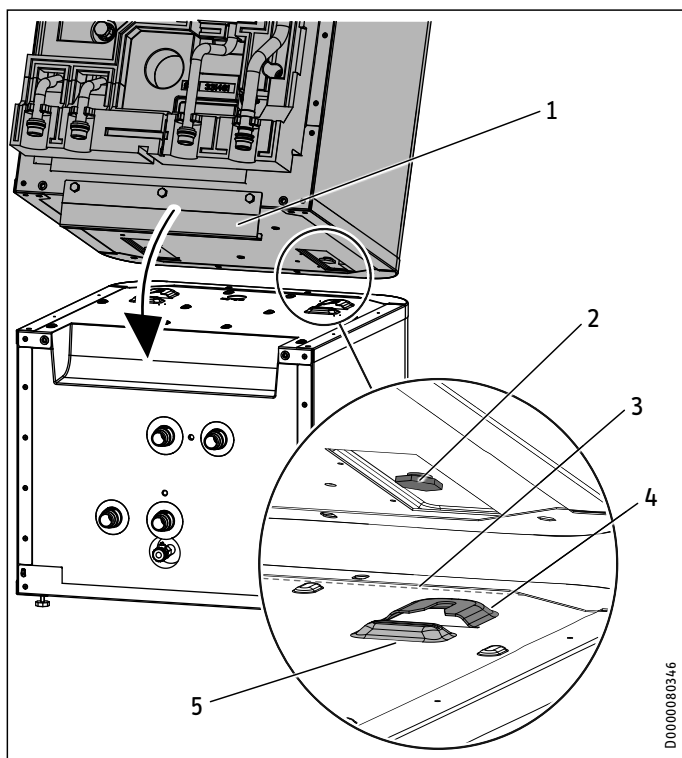

D0000080346

- 1 Handle
- 2 Guide pin
- 3 Dotted line (perforation in the panel)
- 4 Guide groove
- 5 Positioning aid

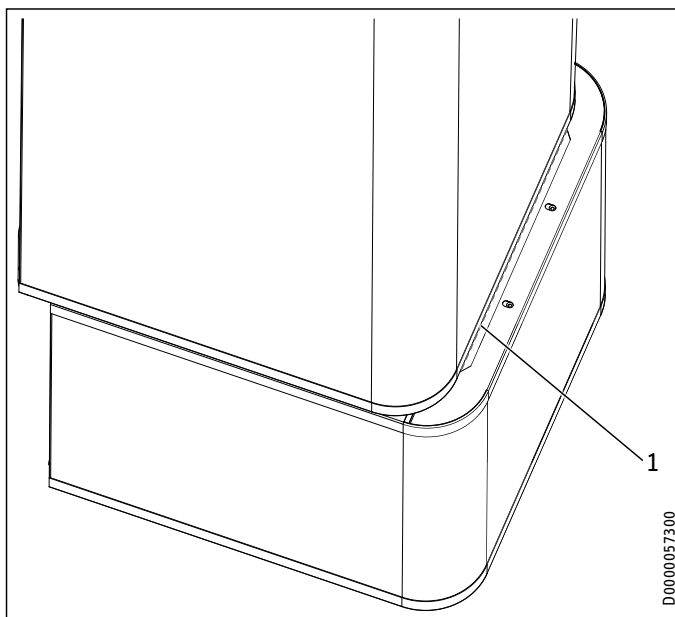

D0000057300

- 1 Dotted line (perforation in the panel)
- ▶ Place the upper appliance section onto the lower appliance section along the dotted line.

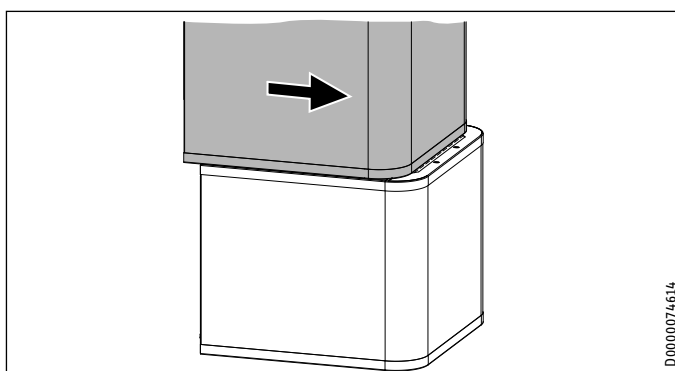

D0000074614

- ▶ Slide the upper appliance section to the back until it is flush with the lower appliance section. If the appliance sections are joined correctly, the final position is determined by the guide groove and guide pin.
- ▶ Secure the tabs on the appliance front.
- ▶ Fit the side profile strips.
- ▶ Fit insulation segment 3 and the 4 hydraulic hoses.
- ▶ Connect the push-fit connectors of the 4 hydraulic connections. Ensure that the spring clips click into place.
- ▶ Insert the "heating sensor" into the buffer tank.
- ▶ Lay the sensor lead in the guide groove provided for this purpose in the insulation segment.
- ▶ Fit insulation segment 2.
- ▶ Fit insulation segment 1.
- ▶ Fit the front casing.

## 10. Installation

### 10.1 Positioning the appliance

- ▶ When positioning the appliance, observe minimum clearances (see chapter "Preparations / Installation site").
- ▶ Use the adjustable feet to compensate for any unevenness in the floor.

### 10.2 Heating water connection



#### Material losses

The heating system to which the appliance is connected must be installed by a qualified contractor in accordance with the water installation drawings in the technical guides.



#### Material losses

When fitting additional shut-off valves, install a further safety valve in an accessible location on the heat generator itself or in the flow line in close proximity to the heat generator. There must not be a shut-off valve between the heat generator and the safety valve.

#### Oxygen diffusion



#### Material losses

Do not use open vented heating systems. Use oxygen diffusion-proof pipes in underfloor heating systems with plastic pipework.

In underfloor heating systems with plastic pipes that are permeable to oxygen and in open vented heating systems, oxygen diffusion may lead to corrosion on the steel components of the heating system (e.g. on the indirect coil of the DHW tank, on buffer tanks, steel radiators or steel pipes).

- ▶ With heating systems that are permeable to oxygen, separate the heating system between the heating circuit and the buffer tank.



#### Material losses

The products of corrosion (e.g. rusty sludge) can settle in the heating system components, which may result in a lower output or fault shutdowns due to reduced cross-sections.

#### Supply lines



#### Note

The maximum permissible line length between the appliance and the heat pump will vary, depending on the version of the heating system (pressure drop). As a standard value, assume a maximum line length of 12 ft 9 in (10 m) and a pipe diameter of 1 inch.

- ▶ Thoroughly flush the pipes before connecting the heat pump. Foreign bodies (e.g. welding pearls, rust, sand, sealing material, etc.) can impair the operational reliability of the system.
- ▶ Install the heating water pipes (see chapter "Specification / Dimensions and connections").
- ▶ Protect the flow and return lines against frost with sufficient thermal insulation.
- ▶ Connect the hydraulic connections with flat gaskets.

If the available external pressure difference is exceeded, the pressure drop in the heating system could result in a reduced heating output.

- ▶ When sizing the pipes, ensure that the available external pressure differential is not exceeded (see chapter "Specification / Data table").
- ▶ When calculating the pressure drop, take account of the flow and return lines and the pressure drop of the heat pump. The pressure drop must be covered by the available pressure differential.

#### 10.2.1 HSBC 3-HKM Integral (optional)



#### WARNING Electrocutation

Before starting work on the appliance, disconnect all poles from the power supply and drain the heating circuit via the drain valve on the buffer tank.

To extend the appliance with a heating circuit with mixer, you can install pump assembly HSBC 3-HKM Integral (available as an accessory).

#### Standard delivery

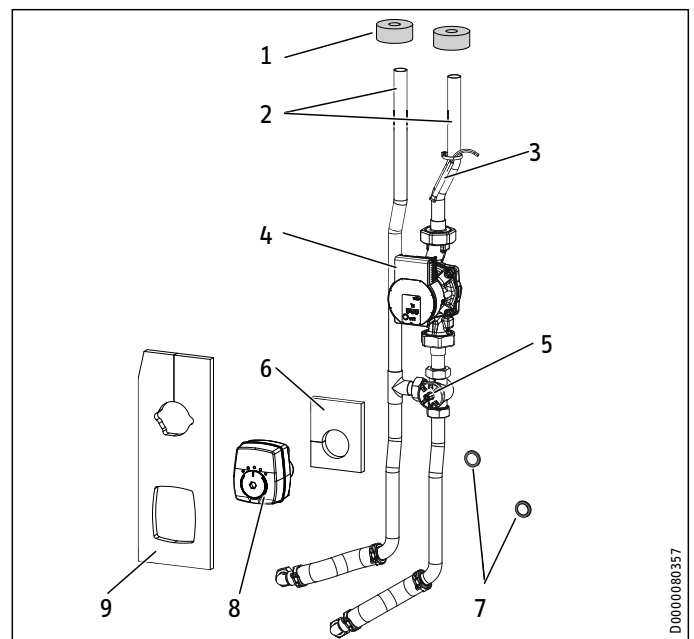

- 1 Pipe insulation
- 2 Connection pipes (\*)
- 3 Temperature sensor
- 4 Heating circuit pump (\*)
- 5 3-way mixer (\*)
- 6 Insulation mat for 3-way mixer

# INSTALLATION

## Installation

- 7 Flat gaskets
- 8 Servomotor for 3-way mixer (\*)
- 9 Insulation mat for 3-way mixer and heating circuit pump
- (\*) Pipe assembly

### Preparation

- ▶ Remove the front casing and insulation segment 1 (see chapter "Installation / Preparations / Transport and handling").

The following components are pre-fitted on the HSBC side at the pump assembly installation site:

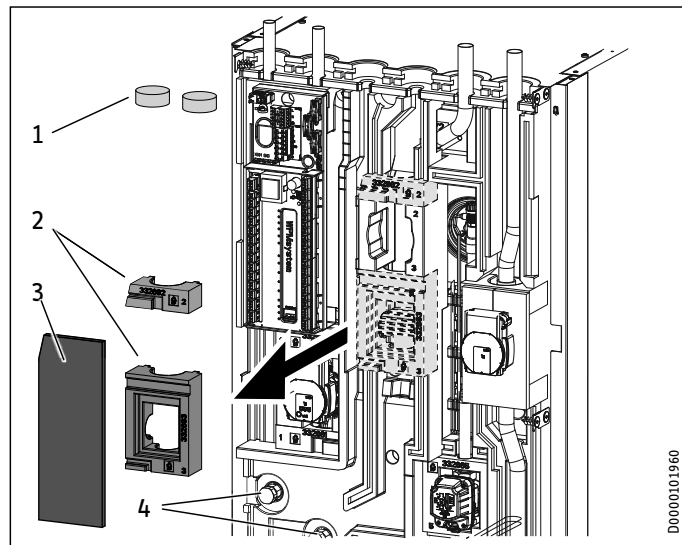

- 1 Insulation plugs
- 2 Profiles for 3-way mixer
- 3 Insulation mat, closed
- 4 Adapter with dummy cap screwed on

- ▶ Remove the insulation plugs.
- ▶ Remove the closed insulation mat and profiles for the 3-way mixer and the heating circuit pump.
- ▶ Counterhold and unscrew the dummy caps from the adapters.

### Installation

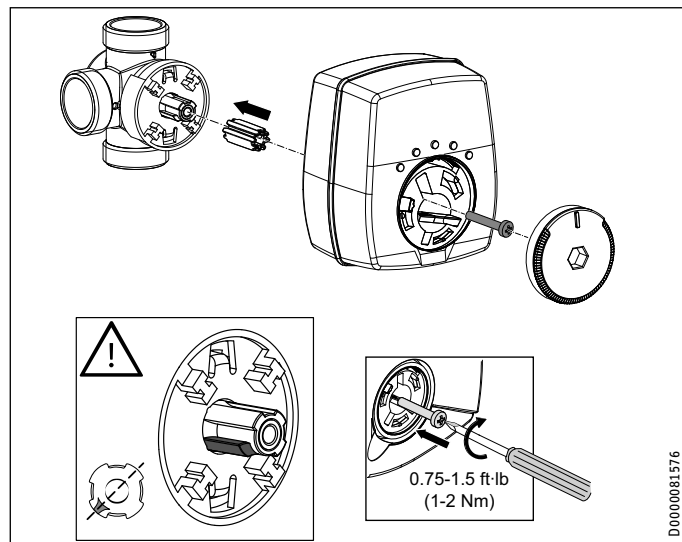

- ▶ Check the position of the 3-way mixer shaft.

- ▶ Adjust the position if necessary.

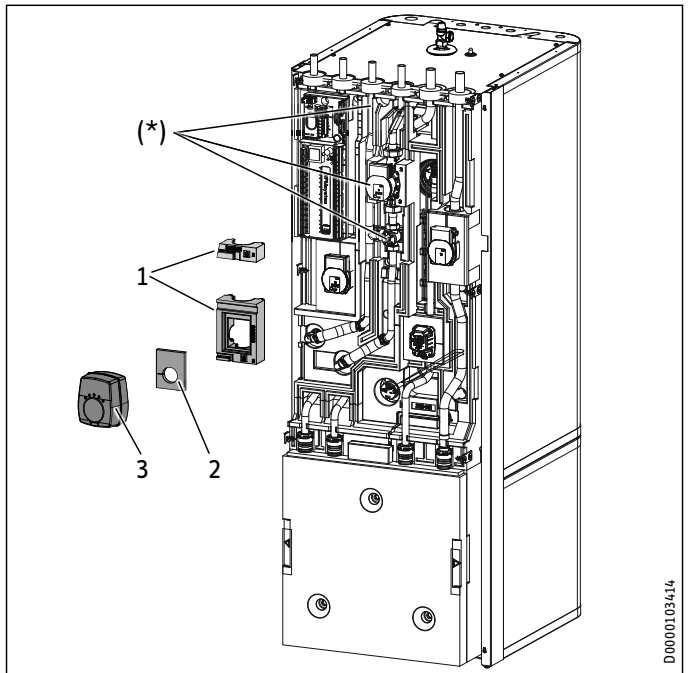

- (\*) Pipe assembly inserted
- 1 Profiles for 3-way mixer
- 2 Insulation mat for 3-way mixer
- 3 Servomotor for 3-way mixer

- ▶ Insert the pipe assembly.
- ▶ Insert the flat gaskets into the union nuts for the connection pipes.
- ▶ Counterhold and secure the union nuts to the adapters.
- ▶ Check the alignment of the pipes and functional elements of the pump assembly.
- ▶ Re-tighten all fittings.
- ▶ Install the profiles for the 3-way mixer over the mixing valve body and above the pump.
- ▶ Place the insulation mat for the 3-way mixer on the valve body.
- ▶ Install the servomotor for the 3-way mixer.

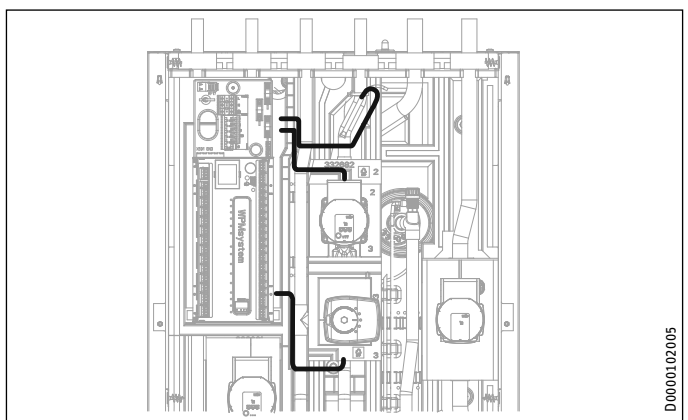

### Material losses

To prevent condensation from forming, do not lay any cables in the joint grooves of the EPP parts.

# INSTALLATION

## Installation

- ▶ Route the pump assembly connecting cable to the control panel as shown.
- ▶ Slide the pipe insulation over the connection pipe connectors from above.

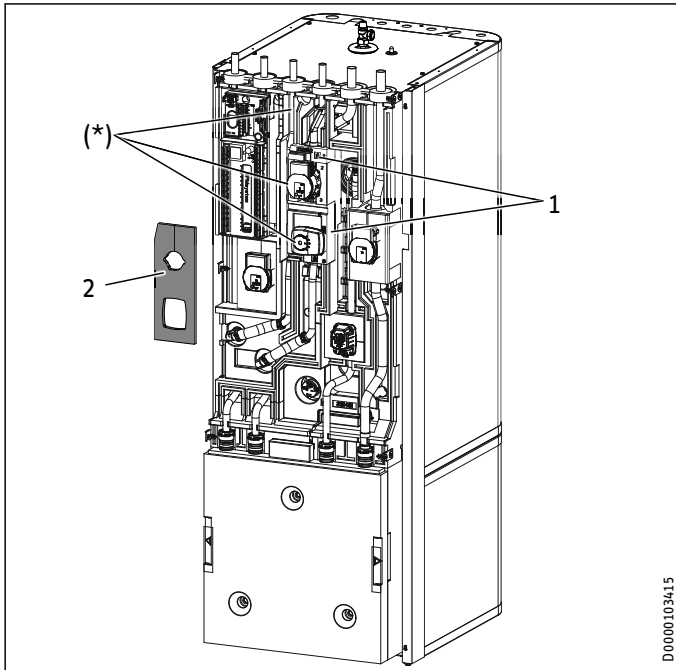

(\*) Pipe assembly inserted

- 1 Profiles for 3-way mixer
- 2 Insulation mat for 3-way mixer and heating circuit pump

- ▶ Insert the insulation mat on the HKM side for the 3-way mixer and the heating circuit pump.
- ▶ Observe the parameter settings in menu "SETTINGS / HEATING / HEATING CIRCUIT 2" in the enclosed commissioning instructions for the heat pump manager.

### 10.3 DHW connection and safety assembly



#### Material losses

The maximum permissible pressure must not be exceeded (see chapter "Specification / Data table").



#### Material losses

Operate the appliance only with pressure-tested taps.

#### Cold water line

Galvanized steel, stainless steel, copper and plastic are approved materials.



#### Material losses

A safety valve is required.

#### DHW line, DHW circulation line

Stainless steel, copper and plastic are approved materials.

#### 10.3.1 DHW connection and safety assembly

- ▶ Flush the pipes thoroughly.

- ▶ Install the DHW outlet line and the cold water inlet line (see chapter "Specification / Dimensions and connections"). Connect the hydraulic connections with flat gaskets.
- ▶ Install a type-tested safety valve in the cold water supply line. Please note that, depending on the supply pressure, you may also need a pressure reducing valve.
- ▶ Size the drain pipe so that water can drain off unimpeded when the safety valve is fully opened.
- ▶ The safety valve drain aperture must remain open to atmosphere.
- ▶ Install the safety valve drain pipe with a constant fall to the drain.

#### 10.3.2 RBS-SBC Integral (optional)



#### WARNING Electrocutation

Before starting work on the appliance, disconnect all poles from the power supply and drain the DHW tank.



#### Note

The following diagrams show pipe assembly RBS-SBC Integral (see chapter "Specification / Dimensions and connections").

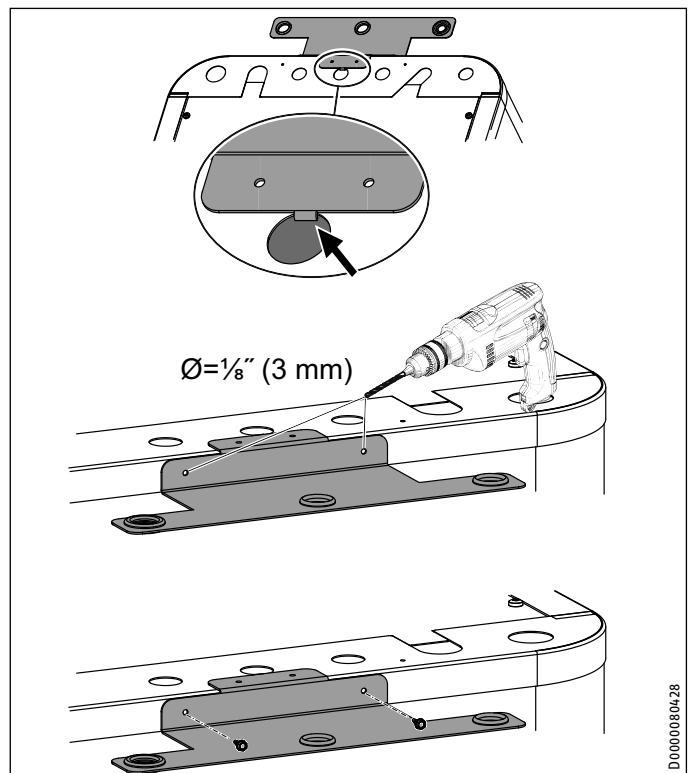

- ▶ Hook the retainer for the connection pipes into the top center of the appliance.
- ▶ Use the retainer as a drilling template and pre-drill the fixing holes.
- ▶ Secure the retainer with the screws.

# INSTALLATION

## Installation

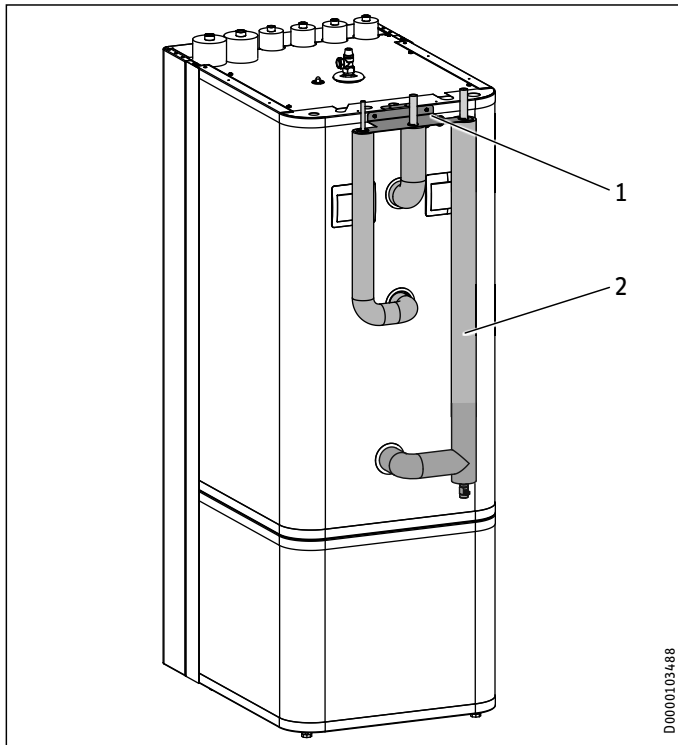

- 1 Retainer  
2 Insulated connection pipes
- ▶ Install the connection pipes in sequence, starting on the left or right depending on the positioning of the appliance.
  - ▶ Insert the connection pipes through the retainer from below.
  - ▶ Secure the connections to the appliance using the union nuts.
  - ▶ Connect the pipes of the pipe assembly to the domestic pipe-work system.

### 10.3.3 DHW circulation line (optional)

A DHW circulation line with external DHW circulation pump can be fitted to the DHW circulation connection (see chapter "Specification / Dimensions and connections").

- ▶ Remove the sealing cap from the DHW circulation connection (see chapter "Specification / Dimensions and connections").
- ▶ Connect the DHW circulation line.

## 10.4 Filling the system

### Heating circuit water quality

Carry out a fill water analysis before filling the system. This analysis may, for example, be requested from the relevant water supply utility.

To avoid damage as a result of scaling, it may be necessary to soften or desalinate the fill water. The fill water limits specified in chapter "Specification / Data table" must always be observed.

- ▶ Recheck these limits 8-12 weeks after commissioning and during the annual system service.



#### Note

With a conductivity  $>1000 \mu\text{S}/\text{cm}$ , desalination treatment is recommended in order to avoid corrosion.



#### Note

If you treat the fill water with inhibitors or additives, the same limits apply as for desalination.



#### Note

Suitable appliances for water softening, as well as for filling and flushing heating systems, can be obtained via trade suppliers.



#### Material losses

Never switch on the power before filling the system.

### 10.4.1 Flushing out the hot water system

Before turning on the water supply, open all taps. Allow the system to fill and flush out all flux and debris from the installation.

### 10.4.2 Filling the heating system

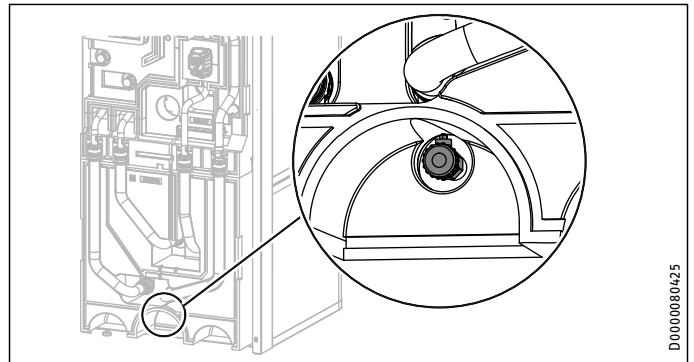

- ▶ Fill the heating system via the drain valve.
- ▶ Vent the pipework.

### 10.4.3 DHW tank filling



#### Material losses

Some fluxes used to solder pipes and fittings need to be flushed out with hot water.

- ▶ Heat the tank to its normal operating temperature and flush all pipe work with hot water to ensure all flux and debris is removed from the system.

- ▶ Open all downstream draw-off valves until the appliance is full and the pipework is free of air.
- ▶ Adjust the flow rate. For this, observe the maximum permissible flow rate with a fully opened tap (see chapter "Specification / Data table"). If necessary reduce the flow rate at the butterfly valve of the safety assembly.
- ▶ Carry out a tightness check.
- ▶ Check the safety valve.

# INSTALLATION

## Electrical connection

### 10.5 Venting the appliance

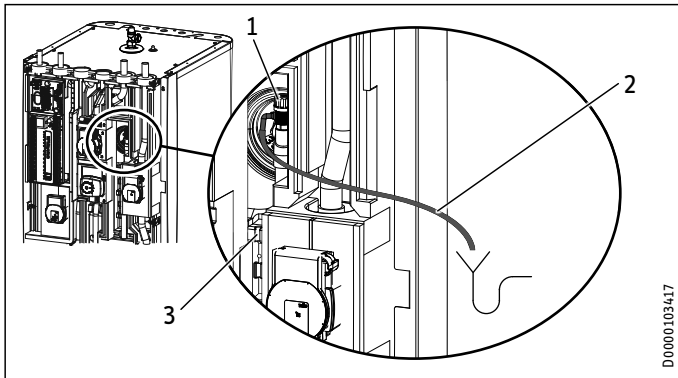

- 1 Air vent valve
- 2 Vent hose
- 3 Hose attachment

- ▶ Detach the vent hose from the hose attachment.
- ▶ Hang the free end of the vent hose in a container.
- ▶ To ventilate, open the air vent valve.
- ▶ After ventilation, close the air vent valve.
- ▶ Secure the vent hose.

### 11. Electrical connection



#### WARNING Electrocutation

Carry out all electrical connection and installation work in accordance with relevant regulations. Before any work on the appliance, disconnect all poles from the power supply.



#### WARNING Electrocutation

The connection to the power supply must be in the form of a permanent connection. Ensure the appliance can be separated from the power supply by an isolator that disconnects all poles with at least 1/8" (3 mm) contact separation. This requirement can be met by using contactors, circuit breakers, fuses/MCBs, etc.



#### Material losses

Provide separate circuit breakers for the two power circuits of the appliance and the control unit.



#### Material losses

Observe the type plate. The specified voltage must match the mains power supply.



#### Note

Leakage currents of up to 5 mA may occur.

The terminal box of the appliance is located behind the front casing (see chapter "Preparations / Transport and handling / Removing/ fitting the front casing").

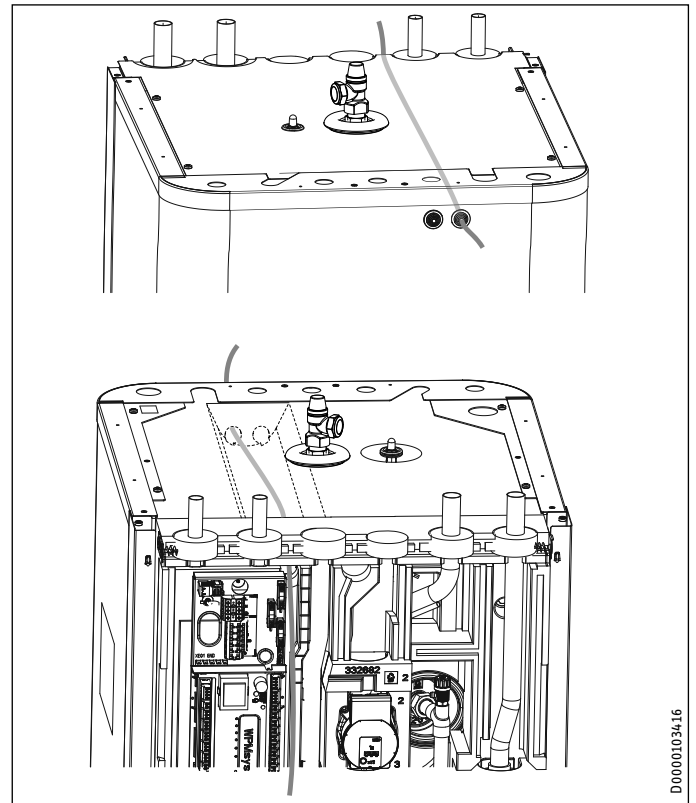

- ▶ Route all power cables and sensor leads into the appliance through the cable entry.
- ▶ Connect the power cables and sensor leads as detailed below.

Install cables with the following cross-sections in accordance with the respective fuse protection:

Circuit breaker	Assignment	Cable cross-section
15 A	Control unit	14 AWG (1.5 mm <sup>2</sup> )

#### 11.1 Control voltage

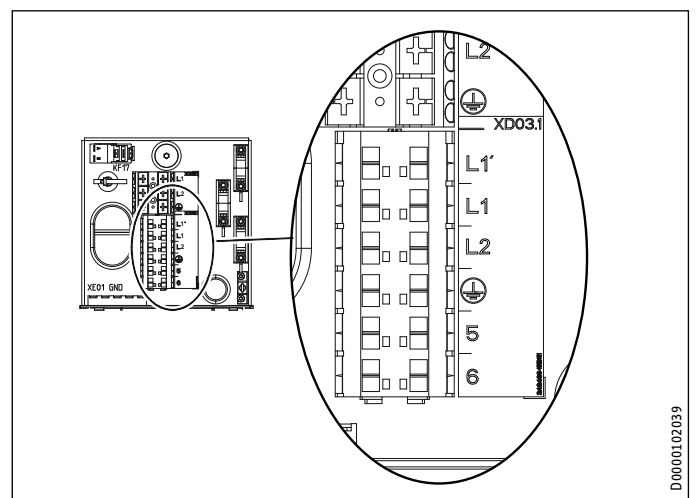

Terminal	Control voltage
XD03.1	Power supply
	L1, L2, GND

### 11.2 Safety extra low voltage

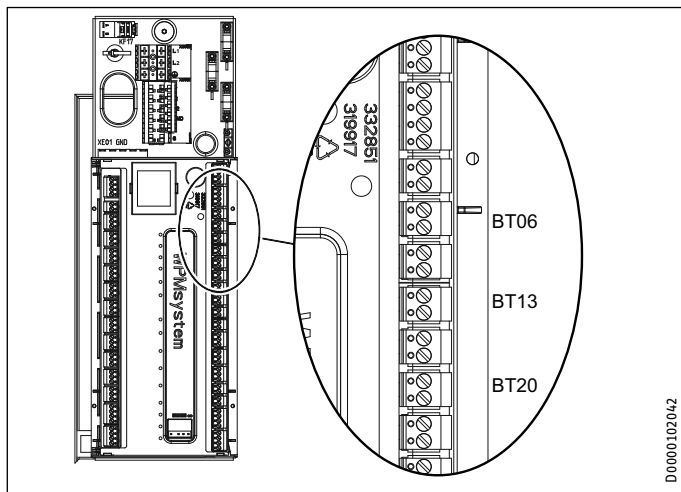

Terminal	Safety extra low voltage
AA01-X1.1	Heat pump
AA01-X1.3	Outside sensor
AA01-X1.4 BT06	Temperature sensor, heat pump, buffer tank
AA01-X1.6 BT13	Temperature sensor, heat pump, flow, heating circuit 2 (HSBC 3-HKM Integral accessory)
AA01-X1.8 BT20	DHW tank temperature sensor

#### Control by WPM via PWM signal

- Observe the information in the commissioning instructions for the WPM heat pump manager.

### 11.3 Heat pump manager terminal assignment



#### WARNING Electrocutation

Only components that operate with safety extra low voltage (SELV) and that ensure secure separation from the mains voltage supply may be connected to the low voltage terminals of the appliance.

Connecting other components can make parts of the appliance and connected components live.

- Only use components which have been approved by us.

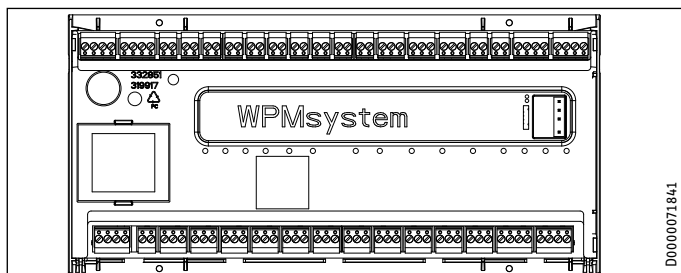

Safety extra low voltage			
X1.1	+	+	CAN (connection for heat pump and WPE heat pump extension)
CAN A	-	-	
	L	L	
	H	H	

#### Safety extra low voltage

X1.2	+	+	CAN (connection for FET remote control and CAN B
	-	-	ISG Internet Service Gateway)
	L	L	
	H	H	
X1.3	Signal	1	Outside sensor
	Ground	2	
X1.4	Signal	1	Buffer sensor (heating circuit sensor 1)
	Ground	2	
X1.5	Signal	1	Flow sensor
	Ground	2	
X1.6	Signal	1	Heating circuit sensor 2
	Ground	2	
X1.7	Signal	1	Heating circuit sensor 3
	Ground	2	
X1.8	Signal	1	DHW tank sensor
	Ground	2	
X1.9	Signal	1	Source sensor
	Ground	2	
X1.10	Signal	1	2nd heat generator (2.WE)
	Ground	2	
X1.11	Signal	1	Cooling flow
	Ground	2	
X1.12	Signal	1	DHW circulation sensor
	Ground	2	
X1.13	Signal	1	Telephone remote switch / heating curve optimization / SG Ready
	Ground	2	
	Signal	3	
X1.14	Constant 12 V	+	Analog input 0-10 V
	Input	IN	
	GND	↓	
X1.15	Constant 12 V	+	Analog input 0-10 V
	Input	IN	
	GND	↓	
X1.16	Signal	1	PWM output 1
	Ground	2	
X1.17	Signal	1	PWM output 2
	Ground	2	
X1.18	+	+	CAN (FES)
CAN B	-	-	
	L	L	
	H	H	
X1.19	+	+	CAN (connection for heat pump and WPE heat pump extension)
CAN A	-	-	
	L	L	
	H	H	

#### Mains power supply

X2.1	L1	L1	Power supply
	L1	L1	
	L2	L2	
	GND	⊕	
X2.2	L1' (power supply utility input)	L1' (pumps)	L1' (power supply utility input)
	L1* (pumps L1)	L1)	L1* (pumps L1)
X2.3	L1	L1	Heating circuit pump 1
	L2	L2	
	GND	⊕ GND	
X2.4	L1	L1	Heating circuit pump 2
	L2	L2	
	GND	⊕ GND	
X2.5	L1	L1	Heating circuit pump 3
	L2	L2	
	GND	⊕ GND	
X2.6	L1	L1	Buffer charging pump 1
	L2	L2	
	GND	⊕ GND	
X2.7	L1	L1	Buffer charging pump 2
	L2	L2	
	GND	⊕ GND	



# INSTALLATION

## Electrical connection

Mains power supply			
X2.8	L1	L1	DHW charging pump
	L2	L2	
	GND	⊕ GND	
X2.9	L1	L1	Source pump / defrost
	L2	L2	
	GND	⊕ GND	
X2.10	L1	L1	Fault output
	L2	L2	
	GND	⊕ GND	
X2.11	L1	L1	DHW circulation pump / 2nd heat source DHW
	L2	L2	
	GND	⊕ GND	
X2.12	L1	L1	2nd heat source heating
	L2	L2	
	GND	⊕ GND	
X2.13	L1	L1	Cooling
	L2	L2	
	GND	⊕ GND	
X2.14	Mixer OPEN	▲	Mixer, heating circuit 2 (X2.14.1 Mixer OPEN X2.14.2 Mixer CLOSE)
	L2	L2	
	GND	⊕ GND	
	Mixer CLOSE	▼	
X2.15	Mixer OPEN	▲	Mixer heating circuit 3 (X2.15.1 Mixer OPEN X2.15.2 Mixer CLOSE)
	L2	L2	
	GND	⊕ GND	
	Mixer CLOSE	▼	



### Note

For every appliance fault, output X2.10 issues a 230 V signal.

In the case of temporary faults, the output switches the signal through for a specific time.

In the case of faults that result in a permanent appliance shutdown, the output switches through permanently.

## 11.4 Accessories

### 11.4.1 HSBC 3-HKM Integral (optional)

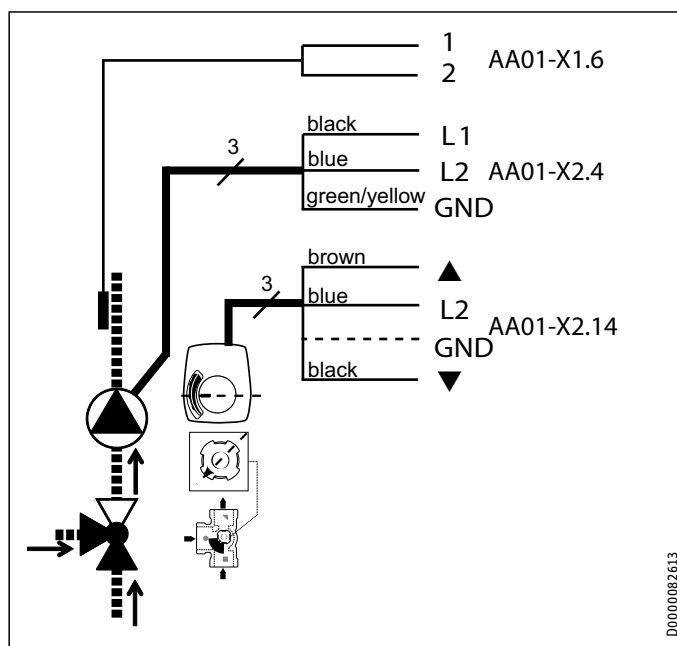

Terminal	Safety extra low voltage
AA01-X1.6	BT13 Temperature sensor, heat pump flow, heating circuit 2

Terminal	Mains power supply
AA01-X2.4	L1, L2, GND MA11 Motor, pump, heating circuit
AA01-X2.14	L1, L1, L2 MA19 Motor, mixing valve heating circuit 2

- ▶ Make the electrical connection for the components.

## 11.5 Sensor installation

### 11.5.1 AF PT outside temperature sensor

- ▶ When installing the outside temperature sensor, observe the commissioning instructions for the heat pump manager (see chapter "Connecting external components").

### 11.5.2 Temperature sensor for area cooling (optional)

Area cooling requires the fitting of a temperature sensor, available as an accessory.

- ▶ Remove the front casing (see chapter "Preparations / Transport and handling / Removing/fitting the front casing").

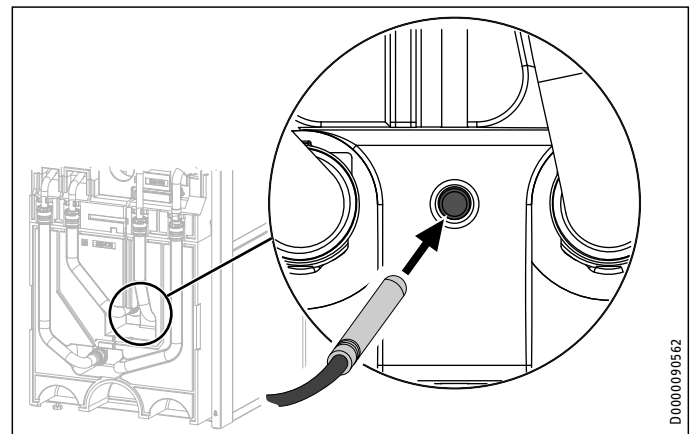

- ▶ Insert the temperature sensor into the sensor well "Sensor heat pump cooling, optional".

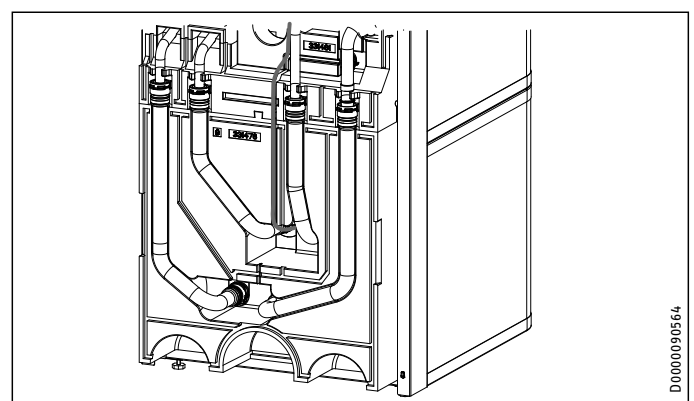

- ▶ Lay the sensor lead in the guide groove provided for this purpose in the insulation segment.
- ▶ Connect the temperature sensor to the corresponding terminal on the WPM (see chapter "Electrical connection / Heat pump manager terminal assignment").

## 11.6 Remote control

- ▶ When installing the remote control unit, observe the commissioning instructions for the heat pump manager (see chapter "Connecting external components").

### 12. Commissioning

#### 12.1 Checks before commissioning the heat pump manager

**Material losses**  
Observe the maximum system temperature in underfloor heating systems.

- ▶ Check that the heating system is filled to the correct pressure and the quick-action air vent valve is closed.
- ▶ Check whether the outside temperature sensor is correctly placed and connected.
- ▶ Check whether the power supply is connected correctly.
- ▶ Check whether the signal cable to the heat pump (bus cable) is correctly connected.

#### 12.2 Commissioning the heat pump manager

Commission the heat pump manager and make all settings in accordance with the heat pump manager commissioning instructions.

**Note**  
For DHW mode, ensure that the PARALLEL OPERATION option is set in the heat pump manager. With this setting the primary pump is also active in DHW mode.

Requirement: The heat pump manager has recognized the heat pump.

- ▶ Open the menu and enter the code.

Parameter	Code
VIEW (SETTINGS)	1 0 0 0

- ▶ Adjust the parameters.

Parameter	Setting
DHW MODE (SETTINGS / DHW / STANDARD SETTING)	PARALLEL OPERATION
FUNCTION (COMMISSIONING / I/O CONFIGURATION / OUTPUT X1.16)	PWM 100%...0%
PUMP (COMMISSIONING / I/O CONFIGURATION / OUTPUT X1.16)	CHARGING PUMP CONTROL HEATING
DHW PUMP RATE (COMMISSIONING / DHW)	100%

#### Setting for single-phase operation

**Note**  
On appliances with a single phase connection, set the heat pump manager as follows for calculating the amount of heat.

- ▶ Adjust the parameters.

Parameter	Setting
NUMBER OF STAGES (SETTINGS / HEATING / ELECTRIC BOOSTER HEATER)	2

#### Area cooling setting

**Material losses**  
Condensation caused by the temperature falling below the dew point can lead to material losses. The appliance is therefore approved exclusively for area cooling.





- ▶ When making the area cooling settings, observe the information in the commissioning instructions for the heat pump manager.

### 13. Settings



#### 13.1 Wilo-Para .../Sc circulation pumps

- ▶ Set the operating mode of the pump depending on the heat distribution system.

#### LED indicators

	Operation indicator: LED illuminates green in normal operation LED illuminates/flashes when there is a fault
	Display of selected control mode $\Delta p-v$ , $\Delta p-c$ and constant speed
	Display of selected curve (I, II, III) within the control mode
	Combinations of LED displays for venting function, manual re-start and key lock

#### Operating button

	<b>Press</b> Selecting the control mode To select the curve (I, II, III) within the control mode
	<b>Press and hold</b> To activate the venting function (press for 3 seconds) Manual restart (press for 5 seconds) To lock/unlock the buttons (press for 8 seconds)

#### Control modes and functions

**Variable differential pressure  $\Delta p-v$  (I, II, III)**  
Recommended for two-pipe heating systems with radiators to reduce flow noise at thermostatic valves

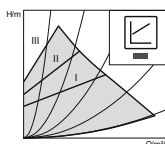

The pump reduces the delivery head by half when the flow rate in the pipework decreases. Saves energy by matching the delivery head to the flow rate demand and the lower flow velocities. Choice of three pre-defined curves (I, II, III).

**Constant pressure differential  $\Delta p-c$  (I, II, III)**

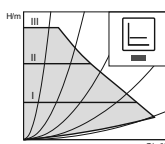

Recommended for underfloor heating systems, large pipework or any application with a non-varying pipe-work curve (e.g. tank charging pumps), as well as single-pipe heating systems with radiators

The control system keeps the set delivery head constant, irrespective of delivered flow rate. Choice of three pre-defined curves (I, II, III).

## Appliance handover

### Constant speed (I, II, III)

Recommended for systems with unchanging system resistance which require a constant throughput.

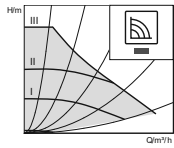

The pump runs at three preset fixed speed levels (I, II, III).



**Note**  
Factory setting: Constant speed, curve III

### Venting



Filling and venting the system correctly  
If the pump does not vent automatically:  
Activate the venting function via the operating button, press button for 3 seconds, then release it.  
Venting function starts (duration 10 minutes).  
The top and bottom rows of LEDs flash alternately every second.  
To cancel, press the operating button for 3 seconds.



**Note**  
After venting, the LED indicator displays the previously set pump values.

### Setting control modes

#### Selecting the control mode

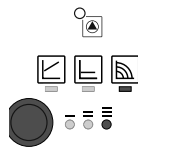

The LEDs for the control modes and associated curves illuminate one after the other.

Briefly press the operating button (for approx. 1 second).  
LEDs indicate the current selected control mode and curve (see following table).

Operating button	LED indicator	Control mode	Curve
1x		Constant speed	II
2x		Constant speed	I
3x		Variable differential pressure $\Delta p-v$	III
4x		Variable differential pressure $\Delta p-v$	II
5x		Variable differential pressure $\Delta p-v$	I
6x		Constant differential pressure $\Delta p-c$	III

Operating button	LED indicator	Control mode	Curve
7x		Constant differential pressure $\Delta p-c$	II
8x		Constant differential pressure $\Delta p-c$	I
*9x		Constant speed	III

(\* ) Pressing the button for the 9th time in succession returns the system to the factory setting (constant speed, curve III).

## 14. Appliance handover

- Explain the appliance function to users and familiarize them with how it works.
- Make users aware of potential dangers.
- Hand over these instructions.

## 15. Shutting down the system



### Material losses

Observe the temperature application limits and the minimum circulation volume on the heat consumer side (see chapter "Specification / Data table").



### Material losses

Drain the system when there is a risk of frost and the heat pump is completely switched off (see chapter "Maintenance / Draining the DHW tank").

- If you take the system out of use, set the heat pump manager to standby so that the safety functions that protect the appliance (e.g. frost protection) remain active.

### 16. Maintenance



**WARNING Electrocutation**  
Carry out all electrical connection and installation work in accordance with relevant regulations.



**WARNING Electrocutation**  
Before any work on the appliance, disconnect all poles of the appliance from the power supply.

#### Draining the buffer tank

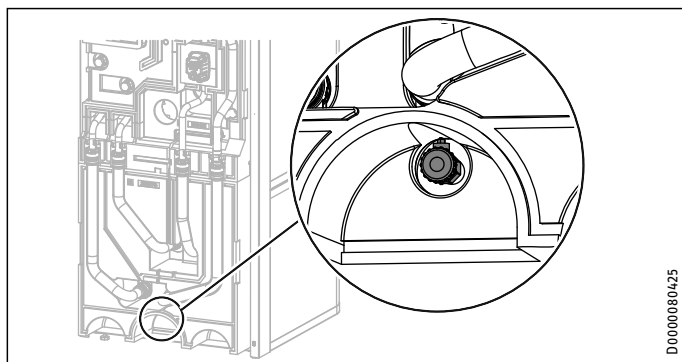

- ▶ Drain the buffer tank via the drain valve.

#### Draining the DHW tank



**CAUTION Burns**  
Hot water may escape during draining.

- ▶ Close the shut-off valve in the cold water supply line.
- ▶ Open the hot water taps on all draw-off points.
- ▶ Empty the DHW tank via the cold water inlet connection.

#### Cleaning and descaling the DHW tank



**Material losses**  
Never use descaling pumps or descaling agents to clean the tank.

- ▶ Clean the appliance through the inspection flange.

For the torque of the flange screws, see chapter "Specification / Dimensions and connections".

#### Replacing the signal anode

- ▶ Replace the signal anode if it becomes depleted.

## 17. Specification

### 17.1 Dimensions and connections

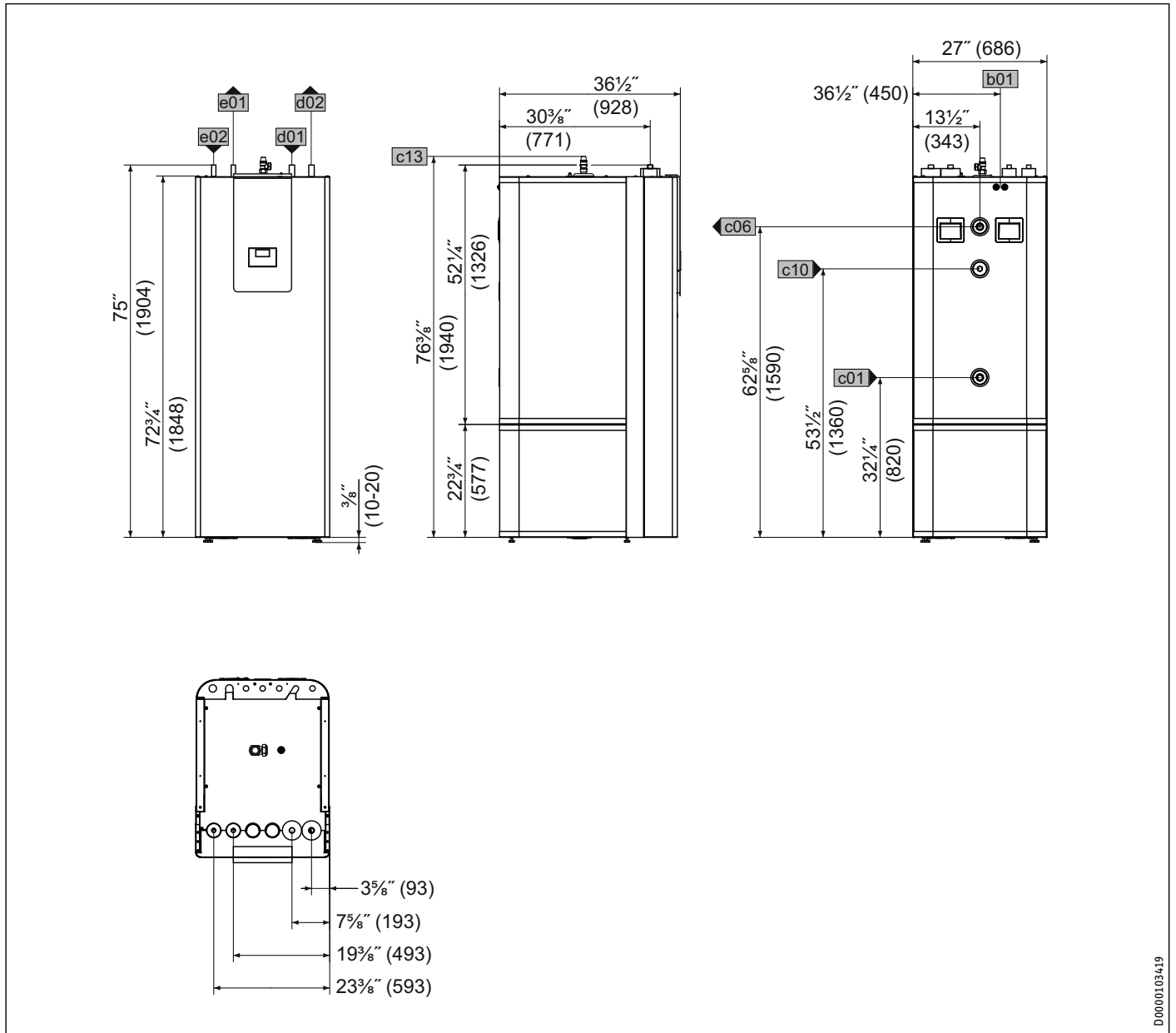

D00001.03419

HSBC 300 Integral		
b01	Entry electrical cables	
c01	Cold water inlet	Male thread G 1"
c06	DHW outlet	Male thread G 1"
c10	DHW circulation	Male thread G 1/2"
c13	T&P valve	
d01	Heat pump flow	Diameter 1" copper
d02	Heat pump return	Diameter 1" copper
e01	Heating flow	Diameter 3/4" copper
e02	Heating return	Diameter 3/4" copper

# INSTALLATION Specification

## Other dimensions and connections

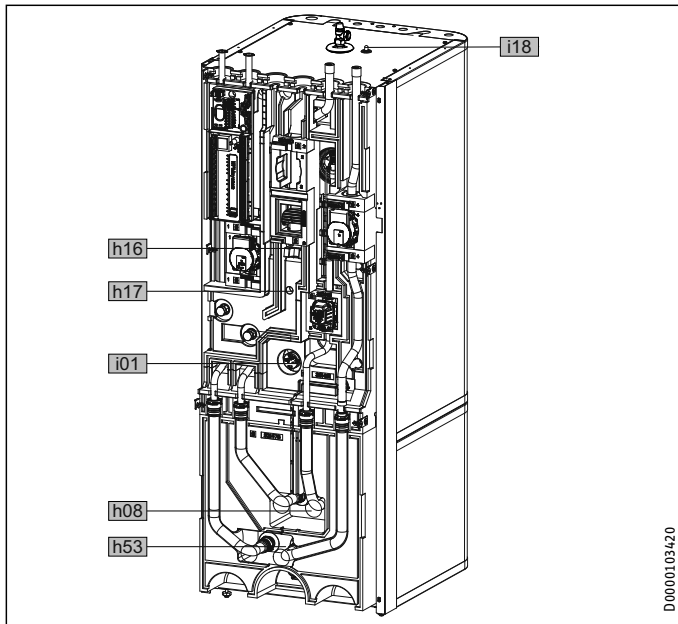

		HSBC 300 Integral	
h08	Sensor, heat pump cooling, optional	Diameter	3/8" (9.5 mm)
h16	Sensor, DHW	Diameter	3/8" (9.5 mm)
h17	Sensor, DHW, optional	Diameter	3/8" (9.5 mm)
h53	Sensor, heating	Diameter	3/8" (9.5 mm)
i01	Flange	External diameter	5 1/2" (140 mm)
		Torque	1/3 ft·lb (45 Nm)
i18	Protective anode	Female thread	G 1 1/4"

## RBS-SBC Integral

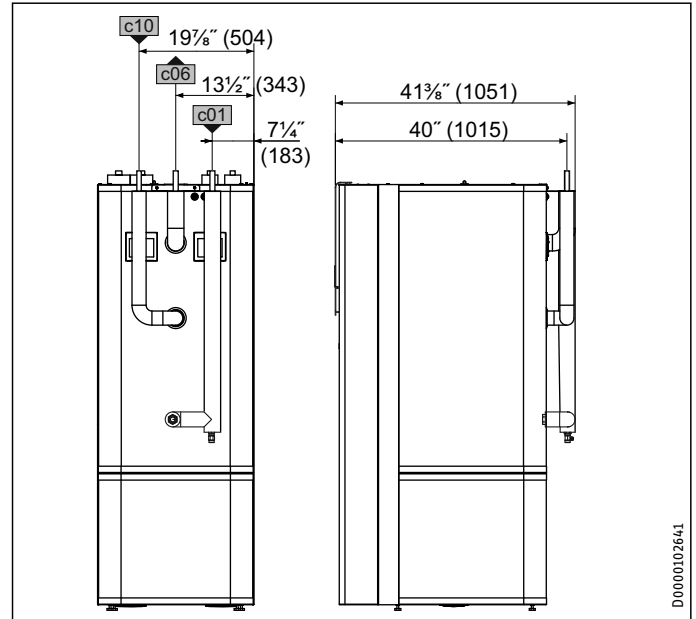

		RBS-SBC Integral	
c01	Cold water inlet	Diameter	3/4" copper
c06	DHW outlet	Diameter	3/4" copper
c10	DHW circulation	Diameter	3/8" copper

## 17.1.1 Accessories

### HSBC 3-HKM Integral

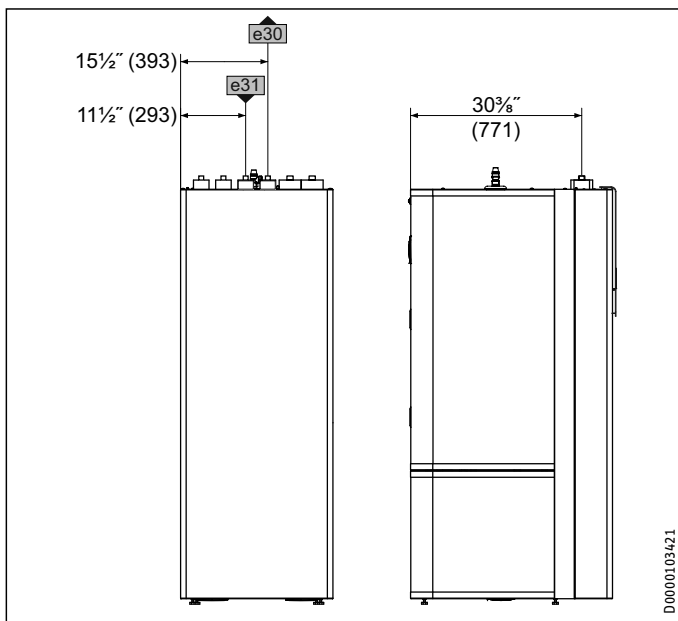

		HSBC 3-HKM Integral	
e30	Heating flow, mixed	Diameter	3/4" copper
e31	Heating return, mixed	Diameter	3/4" copper

## 17.2 Hydraulic diagram

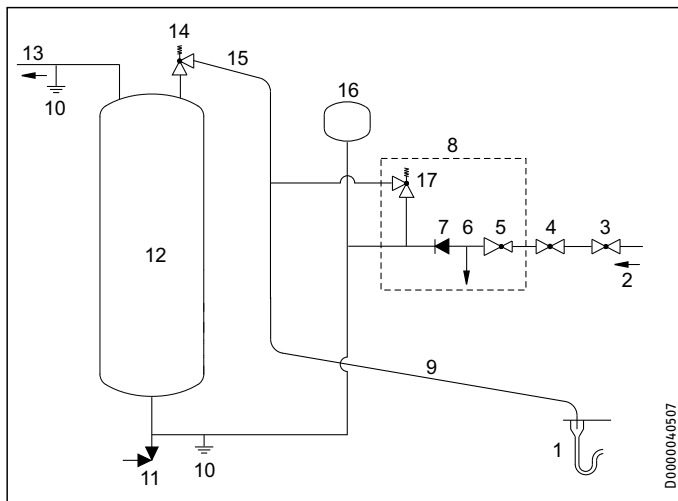

- 1 Discharge below fixed grate
- 2 Cold water supply
- 3 Shut-off valve
- 4 Line strainer
- 5 Pressure reducing valve
- 6 Balanced pressure; cold water outlet
- 7 Check valve
- 8 Safety assembly
- 9 Metal discharge pipe (D2) from tundish, with continuous fall
- 10 Equipotential bond
- 11 Drain valve
- 12 Tank
- 13 DHW outlet
- 14 T&P valve
- 15 Discharge pipe (D1) from T&P valve
- 16 Expansion vessel
- 17 Expansion relief valve



### Material losses

The tundish should be installed away from electrical devices.



### Note

If secondary return circuits are used then an additional expansion vessel may be required.

# INSTALLATION Specification

## 17.3 Wiring diagram

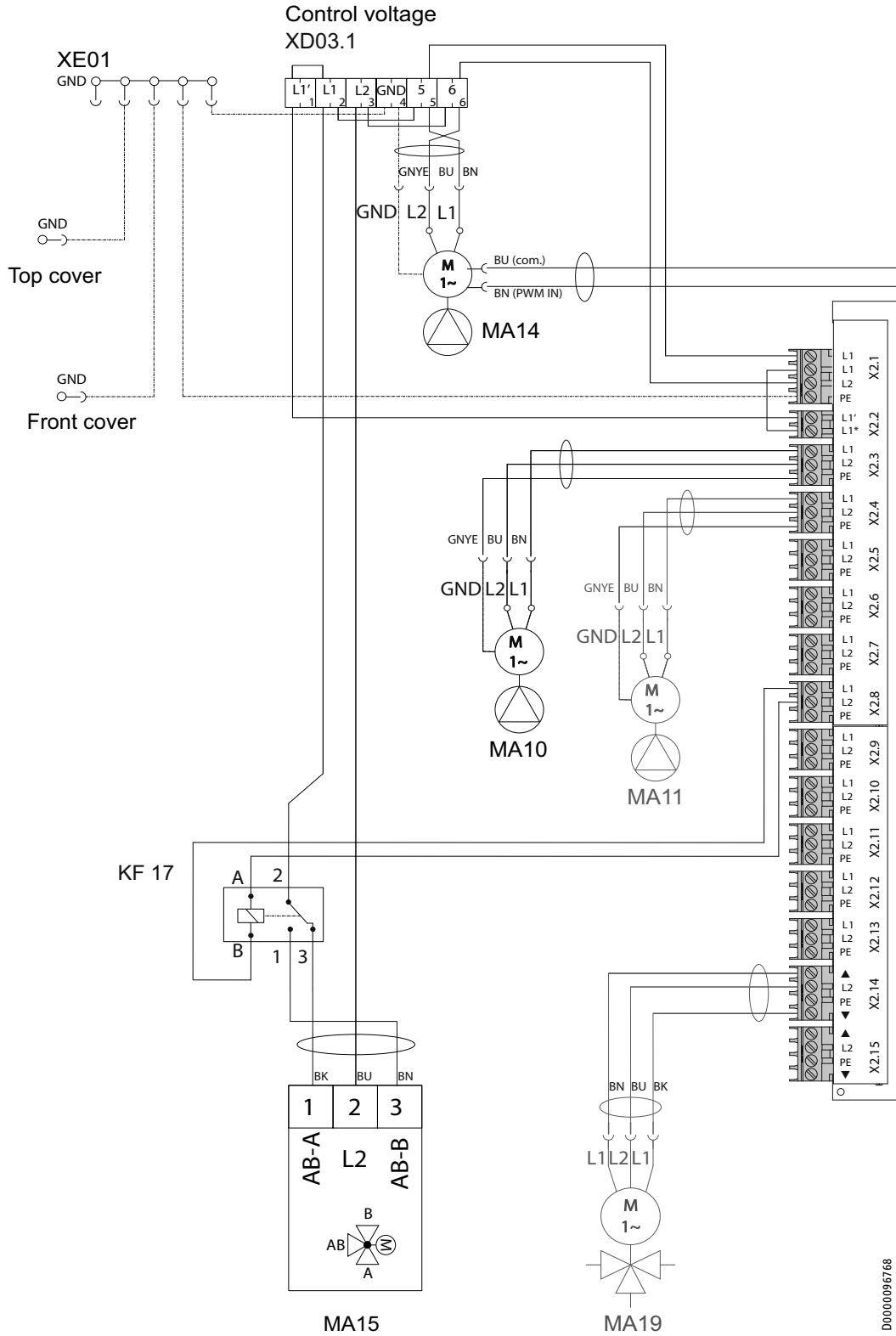

D0000096768



# INSTALLATION Specification

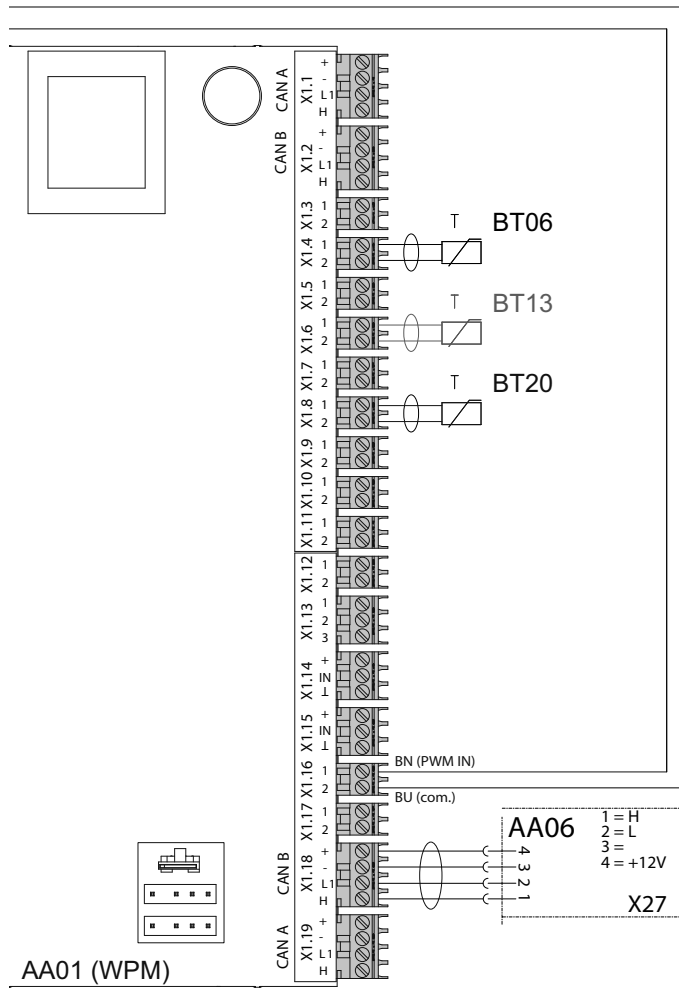

D0000096768

# INSTALLATION

## Specification

AA01		WPM heat pump manager	AA01	X2.14	Connector, mixer, heating circuit 2 (X2.14.1 Mixer OPEN/X2.14.2 Mixer CLOSE)
AA06		Programming unit			
BT06		Temperature sensor, heat pump buffer tank	AA01	X2.15	Connector, mixer, heating circuit 3 (X2.15.1 Mixer OPEN/X2.15.2 Mixer CLOSE)
BT13		Temperature sensor HP flow HC2 (HSBC 3-HKM Integral accessory)	AA06	X27	Terminal, programming unit
BT20		DHW tank temperature sensor	AA07	X60	Connector, temperature sensor, heat pump flow BT01
KF17		Relay, diverter valve, heat source	AA07	X61	Connector, temperature sensor, heat pump return BT02
MA10		Motor, heating circuit pump	AA07	X62	Not assigned – connector, temperature sensor, heat pump return
MA11		Motor, heating circuit pump 2			
MA14		Motor, buffer charging pump (PWM)	AA07	X63	Not assigned – connector, temperature sensor, DHW tank, internal
MA15		Motor, diverter valve, heating/DHW			
MA19		Motor, mixing valve heating circuit 2	AA07	X64	Connector, temperature and flow rate, heating circuit, BF01
XD03.1		Terminal, power supply	AA07	X65	Not assigned
XE01		Power supply ground terminal	AA07	X66	Rast 2.5 connector (heating system pressure) BP01
AA01		Safety extra low voltage	AA07	X67	Not assigned
AA01	X1.1	Connector, CAN A (WP connection)	AA07	X68	Connector, switching, motor, diverter valve central heating / DHW
AA01	X1.2	Connector, CAN B (FET/ISG connection)	AA07	X69	Not assigned
AA01	X1.3	Connector, outside temperature sensor	AA07	X70	Connector, switching, pump, heating circuit PWM/1-10 V
AA01	X1.4	Connector, buffer temperature sensor BT06	AA07	X71	Not assigned
AA01	X1.5	Connector, flow temperature sensor	AA07	X72	Connector, CAN bus
AA01	X1.6	Connector, heating circuit temperature sensor 2			
AA01	X1.7	Connector, heating circuit temperature sensor 3			
AA01	X1.8	Connector, DHW tank sensor BT20			
AA01	X1.9	Connector, source sensor			
AA01	X1.10	Connector, heat source 2			
AA01	X1.11	Connector, flow, cooling			
AA01	X1.12	Connector, DHW circulation sensor			
AA01	X1.13	Connector, remote control FE7			
AA01	X1.14	Connector, analog input 0-10 V			
AA01	X1.15	Connector, analog input 0-10 V			
AA01	X1.16	Connector, PWM output 1			
AA01	X1.17	Connector, PWM output 2			
AA01	X1.18	Connector, CAN B (FET/ISG connection)			
AA01	X1.19	Connector, CAN A (electronic board MFG)			
AA01		Mains voltage			
AA01	X2.1	Connector, power supply			
AA01	X2.2	Connector, power supply utility input			
AA01	X2.3	Connector, heating circuit pump 1			
AA01	X2.4	Connector, heating circuit pump 2			
AA01	X2.5	Connector, heating circuit pump 3			
AA01	X2.6	Connector, buffer charging pump 1			
AA01	X2.7	Connector, buffer charging pump 2			
AA01	X2.8	Connector, DHW charging pump			
AA01	X2.9	Connector, source pump/defrost			
AA01	X2.10	Connector, fault output			
AA01	X2.11	Connector, DHW circulation pump / 2nd heat source – DHW			
AA01	X2.12	Connector, 2nd heat source – heating			
AA01	X2.13	Connector, cooling			

# INSTALLATION Specification

## 17.4 Sample installation

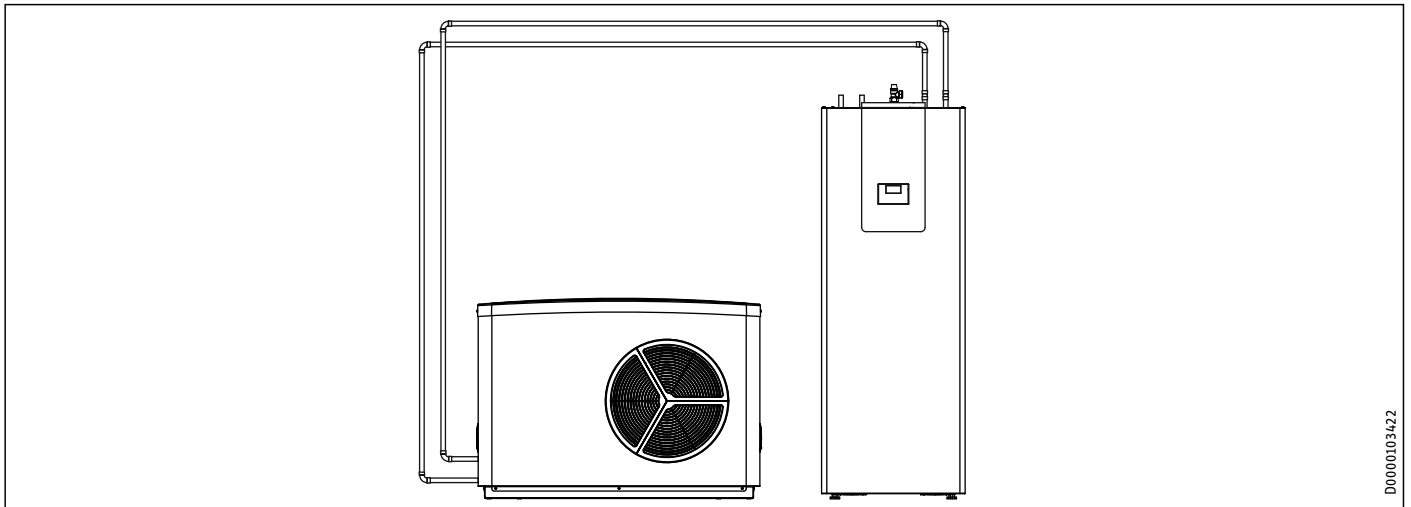

D0000103422

## 17.5 Data table

	HSBC 300 Integral
	202493
<b>Hydraulic data</b>	
Nominal capacity, DHW tank	71.3 gal (270 l)
Nominal capacity, buffer tank	26.4 gal (100 l)
Surface area, heat exchanger	34.4 ft <sup>2</sup> (3.20 m <sup>2</sup> )
Volume, heat exchanger	5.5 gal (21 l)
External available pressure differential, circulation pump, heat pump at 4.4 gpm (1.0 m <sup>3</sup> /hr)	22.0 ft. head (656 hPa)
External available pressure differential, circulation pump, heat pump at 6.6 gpm (1.5 m <sup>3</sup> /hr)	17.6 ft. head (527 hPa)
External available pressure differential, circulation pump, heat pump at 8.8 gpm (2.0 m <sup>3</sup> /hr)	7.0 ft. head (210 hPa)
External available pressure differential, circulation pump, heating circuit 1 at 4.4 gpm (1.0 m <sup>3</sup> /hr)	24.3 ft. head (725 hPa)
External available pressure differential, circulation pump, heating circuit 1 at 6.6 gpm (1.5 m <sup>3</sup> /hr)	22.2 ft. head (663 hPa)
External available pressure differential, circulation pump, heating circuit 1 at 8.8 gpm (2.0 m <sup>3</sup> /hr)	14.9 ft. head (444 hPa)
External available pressure differential, circulation pump, heating circuit 2 (optional) at 4.4 gpm (1.0 m <sup>3</sup> /hr)	22.3 ft. head (665 hPa)
External available pressure differential, circulation pump, heating circuit 2 (optional) at 6.6 gpm (1.5 m <sup>3</sup> /hr)	17.3 ft. head (518 hPa)
External available pressure differential, circulation pump, heating circuit 2 (optional) at 8.8 gpm (2.0 m <sup>3</sup> /hr)	6.3 ft. head (189 hPa)
Pressure drop at 4.4 gpm (1.0 m <sup>3</sup> /h), heat exchanger, top	1.9 ft. head (56 hPa)
Reheating time, top heat exchanger	33 min
<b>Application limits</b>	
Max. permissible pressure (design pressure), DHW	101.5 psi (0.7 MPa)
Max. permissible pressure (design pressure), heat exchanger, top	43.5 psi (0.3 MPa)
Test pressure, DHW tank	217.6 psi (1.50 MPa)
Max. flow rate	6.6 gpm (25 l/min)
Max. permissible pressure (design pressure), buffer tank	43.5 psi (0.3 MPa)
Test pressure, buffer tank	65.3 psi (0.45 MPa)
Maximum permissible temperature	192 °F (89 °C)
Maximum altitude for installation	6562 ft. (2000 m)

	HSBC 300 Integral
<b>Heating water quality requirements</b>	
Water hardness	≤50 ppm
pH value (with aluminum fittings)	8.0-8.5
pH value (without aluminum fittings)	8.0-10.0
Conductivity (softening)	< 1000 μS/cm
Conductivity (desalination)	20-100 μS/cm
Chloride	<30 ppm (<30 mg/l)
Oxygen 8-12 weeks after filling (softening)	<0.02 ppm (<0.02 mg/l)
Oxygen 8-12 weeks after filling (desalination)	<0.1 ppm (<0.1 mg/l)
<b>Power consumption</b>	
Max. power consumption, charging pump	60 W
Max. power consumption, circulation pump, heating side	60 W
<b>Energy data</b>	
Standby energy consumption/ 24 h at 149 °F (65 °C)	1.45 kWh
<b>Electrical data</b>	
Rated voltage, control unit	220-240 V
Phase, control unit	L1/L2/GND
Control unit circuit breaker	1 x 15 A
Frequency	60 Hz
<b>Values</b>	
Nominal heating flow rate at A-7/W35 and 7 K	6.2 gpm (23.3 l/min)
Min. flow rate, heating	3.1 gpm (11.7 l/min)
Safety assembly, max. supply pressure	145 psi (1.0 MPa)
Recommended operating pressure, heating circuit	29 psi (0.2 MPa)
Recommended operating pressure, DHW	50.8 psi (0.35 MPa)
Pressure reducer, set value	50.8 psi (0.35 MPa)
T&P valve, nominal set temperature	194 °F (90 °C)
T&P valve, nominal set pressure	101.5 psi (0.7 MPa)
T&P valve, nominal diameter	3/4"
Expansion valve, nominal set pressure	87 psi (0.6 MPa)
Expansion vessel, DHW - pre-charge pressure	50.8 psi (0.35 MPa)
Expansion vessel, DHW - volume	3.2 gal (12 l)
<b>Versions</b>	
IP rating	IP20

---

# INSTALLATION

## Specification

---

	HSBC 300 Integral
<b>Dimensions</b>	
Height	75½" (1918 mm)
Width	26¾" (680 mm)
Depth	35⅞" (910 mm)
Height when tilted	83⅝" (2123 mm)
<b>Weights</b>	
Weight, full	1413 lb (641 kg)
Weight, empty	551 lb (250 kg)

### 17.6 Accessories

#### Pipe assembly RBS-SBC Integral

	RBS-SBC Integral
	203798
<b>Connections</b>	
Cold water connection	¾" copper pipe
DHW connection	¾" copper pipe
Connection, DHW circulation	⅜" copper pipe
<b>Versions</b>	
Suitable for	HSBC 300 Integral

#### Pump assembly HSBC 3-HKM Integral

	HSBC 3-HKM Integral
	203799
<b>Connections</b>	
Connection, heating circuit	¾" copper pipe

---

## NOTES

---

---

NOTES

---

# HSBC Integral

All Models

## LIMITED WARRANTY

Subject to the terms and conditions set forth in this limited warranty, Stiebel Eltron, Inc. (the "Manufacturer") hereby warrants to the original purchaser (the "Owner") that each HSBC Integral (the "Product") shall not fail due to defects in the Manufacturer's materials or workmanship in ("Residential applications") defined as single family dwellings or duplexes; for personal use by occupants of a domicile for a period of:

(7) years - Leaks in or emanating from the internal domestic hot water tank

(2) years - All other parts

As Owner's sole and exclusive remedy for breach of the above warranty, Manufacturer shall, at the Manufacturer's discretion, send replacement parts for local repair, or replace the defective Product with a replacement unit with comparable operating features. Manufacturer's maximum liability under all circumstances shall be limited to the Owner's purchase price for the Product. All replacement compressors or parts shall be warranted for the remainder of the original warranty period.

Warranty coverage exclusions:

1. All labor costs for diagnostics, repair, replacement of parts, and removal of the product for any reason;
2. The product must be installed by a licensed HVAC Contractor;
3. Installation of the Product other than as directed by Manufacturer and other than in accordance with all applicable local and state building codes;
4. Failure to maintain the Product or to operate the Product in accordance with the Manufacturer's specifications;
5. Improper installation of the Product and/or improper materials used by any installer and not relating to defects in parts or workmanship of Manufacturer;

6. Moving the Product from its original place of installation;
7. Damage to the Product by acts of God and circumstances over which Manufacturer has no control including vandalism
8. Connecting the Product to any incompatible third party component or system;
9. Installing the Product in an environment where it will be exposed to corrosive and caustic substances;
10. Exposing the Product to freezing conditions;
11. Supplying the Product with non-potable water or water that is corrosive, hard, or contaminated with pollutants or additives;
12. Not properly draining the Product during power outages lasting longer than two days;
13. Connecting the Product to improper voltage or service;

Should owner wish to return the Product to manufacturer for replacement under this warranty, Owner must first secure written authorization from Manufacturer. Owner shall demonstrate proof of purchase, including a purchase date, and shall be responsible for all removal and transportation costs. If Owner cannot demonstrate a purchase date this warranty shall be limited to the period beginning from the date of manufacture stamped on the Product. Manufacturer reserves the right to deny warranty coverage upon Manufacturer's examination of the Product. This warranty is restricted to the Owner and cannot be assigned. Any defective part replaced under this warranty shall become the property of Manufacturer and returned for inspection.

Some States and Provinces do not allow the exclusion or limitation of certain warranties. In such cases, the limitations set forth herein may not apply to the Owner. In such cases this warranty shall be limited to the shortest period and lowest damage amounts allowed by law. This warranty gives you specific legal rights and you may also have other rights which vary from State to State or Province to Province.

This Warranty is valid for U.S.A. & Canada only. Warranties may vary by country. Please consult your local Stiebel Eltron Representative for the Warranty for your country.

## United States of America

STIEBEL ELTRON, Inc.  
17 West Street | West Hatfield, MA 01088  
Tel. 413.247.3380 | Fax 413.247.3369  
Toll-free 800.582.8423  
info@stiebel-eltron-usa.com  
www.stiebel-eltron-usa.com

## Austria

STIEBEL ELTRON Ges.m.b.H.  
Eferdinger Str. 73 | 4600 Wels  
Tel. 07242 47367-0 | Fax 07242 47367-42  
info@stiebel-eltron.at  
www.stiebel-eltron.at

## Belgium

STIEBEL ELTRON bvba/sprl  
't Hofveld 6 - D1 | 1702 Groot-Bijgaarden  
Tel. 02 42322-22 | Fax 02 42322-12  
info@stiebel-eltron.be  
www.stiebel-eltron.be

## Czech Republic

STIEBEL ELTRON spol. s r.o.  
K Háji 946 | 155 00 Praha 5 - Stodůlky  
Tel. 251116-111 | Fax 235512-122  
info@stiebel-eltron.cz  
www.stiebel-eltron.cz

## Denmark

Pettinaroli A/S  
Mandal Allé 21 | 5500 Middelfart  
Tel. 06341 666-6 | Fax 06341 666-0  
info@pettinaroli.dk  
www.stiebel-eltron.dk

## Finland

Insinöörtoimisto Olli Andersson Oy  
Kapinakuja 1 | 04600 Mäntsälä  
Tel. 020 720-9988 | Fax 020 720-9989  
info@stiebel-eltron.fi  
www.stiebel-eltron.fi

## France

STIEBEL ELTRON SAS  
7-9, rue des Selliers  
B.P 85107 | 57073 Metz-Cédex 3 Tel. 0387  
7438-88 | Fax 0387 7468-26  
info@stiebel-eltron.fr  
www.stiebel-eltron.fr

## Germany

STIEBEL ELTRON GmbH & Co. KG  
Dr.-Stiebel-Straße | 37603 Holzminden  
Tel. 05531 702-0 | Fax 05531 702-480  
info@stiebel-eltron.de  
www.stiebel-eltron.de

## Hungary

STIEBEL ELTRON Kft.  
Pacsirtamező u. 41 | 1036 Budapest Tel.  
01 250-6055 | Fax 01 368-8097  
info@stiebel-eltron.hu  
www.stiebel-eltron.hu

## Japan

NIHON STIEBEL Co. Ltd.  
Ebara building 3F  
2-9-3 Hamamatsu-cho  
Minato-Ku | 105-0013 Tokyo  
Tel. 03 34364662 | Fax 03 34594365  
info@nihonstiebel.co.jp  
www.nihonstiebel.co.jp

## Netherlands

STIEBEL ELTRON Nederland B.V.  
Daviotenweg 36  
5222 BH 's-Hertogenbosch  
Tel. 073 623-0000 | Fax 073 623-1141  
stiebel@stiebel-eltron.nl  
www.stiebel-eltron.nl

## Poland

STIEBEL ELTRON Polska Sp. z o.o. ul.  
Instalatorów 9 | 02-237 Warszawa Tel. 022  
60920-30 | Fax 022 60920-29  
stiebel@stiebel-eltron.com.pl  
www.stiebel-eltron.com.pl

## Russia

STIEBEL ELTRON LLC RUSSIA  
Urzhumskaya street 4,  
building 2 | 129343 Moscow  
Tel. 0495 7753889 | Fax 0495 7753887  
info@stiebel-eltron.ru  
www.stiebel-eltron.ru

## Slovakia

STIEBEL ELTRON Slovakia, s.r.o.  
Hlavná 1 | 058 01 Poprad  
Tel. 052 7127-125 | Fax 052 7127-148  
info@stiebel-eltron.sk  
www.stiebel-eltron.sk

## Sweden

STENERGY  
Vasagatan 14 | 545 30 Töreboda  
Sales:  
Tel. 0506 105-10 | info@stiebel-eltron.se  
Technique & Service:  
Tel. 0150 54200 | info@heatech.se  
www.stiebel-eltron.se

## Switzerland

STIEBEL ELTRON AG  
Netzibodenstr. 23 c | 4133 Pratteln  
Tel. 061 81693-33 | Fax 061 81693-44  
info@stiebel-eltron.ch  
www.stiebel-eltron.ch

## Thailand

STIEBEL ELTRON Asia Ltd.  
469 Moo 2 Tambol Klong-Jik  
Amphur Bangpa-In | 13160 Ayutthaya  
Tel. 035 220088 | Fax 035 221188  
info@stiebel-eltronasia.com  
www.stiebel-eltronasia.com

## United Kingdom and Ireland

STIEBEL ELTRON UK Ltd.  
Unit 12 Stadium Court  
Stadium Road | CH62 3RP Bromborough  
Tel. 0151 346-2300 | Fax 0151 334-2913  
info@stiebel-eltron.co.uk  
www.stiebel-eltron.co.uk

**STIEBEL ELTRON**