

SHC Mini-Tank Electric Water Heater Submittal Sheet

Engineer/Architect: _____ **Date:** _____

Job Name/Customer: _____ **Phone:** _____

Location: _____ **Date Required:** _____

Contractor: _____ **Phone:** _____

Description

SHC Mini-Tank installs right under or near a sink and provides hot water for hand washing or kitchen type applications either as a stand-alone hot water source or as a booster for remote central tank. Lightweight and compact, the SHC mounts to the wall (bracket included), draws 11.3 A and plugs into a 110-120V outlet.

- › T & P valve included
- › Glass-lined tank
- › 1/2" NPT brass water connections
- › Wall-mounted
- › Stainless steel dip tube
- › Plugs into 120V, 15A outlet
- › 6-year warranty on tank /2-year components
- › Reduces standby losses
- › Manufactured in Germany



Specifications

Model	Voltage	Watts	Amps	Nominal Water Vol.	Max. Adj. Temperature	Recovery Time	Standby energy loss
SHC 2.5	120 V	1300 W	11.3 A	2.65 gal (10 l)	140 °F (60 °C)	18 min.	0.37 kW/day ¹
SHC 4	120 V	1300 W	11.3 A	3.96 gal (15 l)	140 °F (60 °C)	27 min.	0.39 kW/day ¹
SHC 6	120 V	1300 W	11.3 A	6.0 gal (22.7 l)	140 °F (60 °C)	45 min.	0.43 kW/day ¹

¹ Measured at 131 °F (55 °C) set point temperature in 68 °F (20 °C) ambient air temperature.

SHC Model	SHC 2.5	SHC 4	SHC 6
Part number	233219	234046	235089
Weight Empty	15.9 lbs (7.2 kg)	19.8 lbs (9.0 kg)	26.5 lbs (12.0 kg)
Height	18 11/16" (475 mm)	19 3/4" (501 mm)	20 1/2" (520 mm)
Width	11" (280 mm)	12 5/8" (320 mm)	15 1/8" (385 mm)
Depth	10 5/8" (270 mm)	12 1/2" (318 mm)	15" (380 mm)
Max. Operating Pressure	150 psi (10 bar)	150 psi (10 bar)	150 psi (10 bar)
Cover Material and Color	Alpine White ABS	Alpine White ABS	Alpine White ABS



Conforms to UL Std. 174
 Certified to CAN/CSA
 Std. C22.2 No. 110



Tested and certified by WQA
 against NSF/ANSI/CAN 372
 for lead free compliance.



Typical Installations

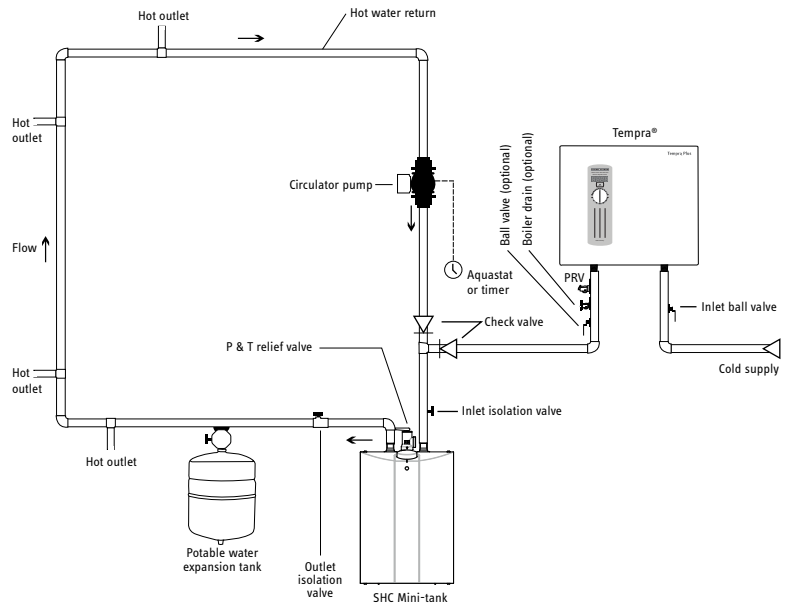
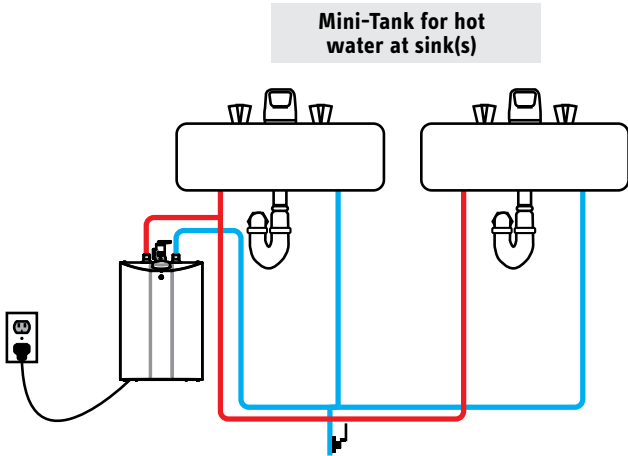
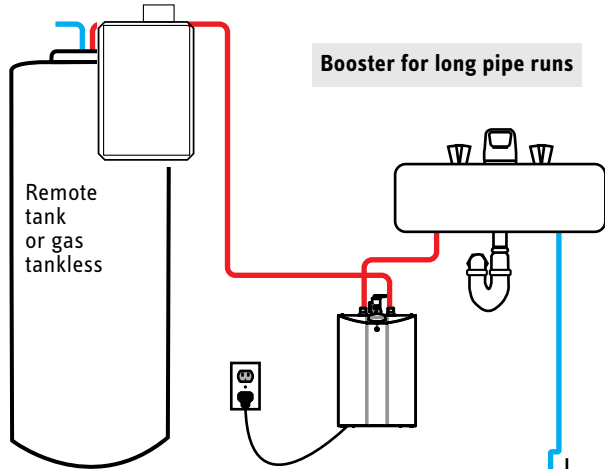

Booster for recirculation loop

Warranty

Limited Warranty: Subject to the terms and conditions set forth in this limited warranty, Stiebel Eltron, Inc. (the “Manufacturer”) hereby warrants to the original purchaser (the “Owner”) that each Mini-Tank Domestic Hot Water Heater (the “Heater”) shall not (i) leak due to defects in the Manufacturer’s materials or workmanship for a period of six (6) years from the date of purchase or (ii) fail due to defects in the Manufacturer’s materials or workmanship for a period of two (2) years from the date of purchase. As Owner’s sole and exclusive remedy for breach of the above warranty, Manufacturer shall, at the Manufacturer’s discretion, send replacement parts for local repair; retrieve the unit for factory repair, or replace the defective Heater with a replacement unit with comparable operating features. Manufacturer’s maximum liability under all circumstances shall be limited to the Owner’s purchase price for the Heater.

This limited warranty shall be the exclusive warranty made by the Manufacturer and is made in lieu of all other warranties, express or implied, whether written or oral, including, but not limited to warranties of merchantability and fitness for a particular purpose. Manufacturer shall not be liable for incidental, consequential or contingent damages or expenses arising directly or indirectly from any defect in the Heater or the use of the Heater. Manufacturer shall not be liable for any water damage or other damage to property of Owner arising, directly or indirectly, from any defect in the Heater or the use of the Heater. Manufacturer alone is authorized to make all warranties on Manufacturer’s behalf and no statement, warranty or guarantee made by any other party shall be binding on Manufacturer.

Manufacturer shall not be liable for any damage whatsoever relating to or caused by:

1. any misuse or neglect of the Heater, any accident to the Heater, any alteration of the Heater, or any other unintended use;
2. acts of God and circumstances over which Manufacturer has no control;
3. installation of the Heater other than as directed by Manufacturer and other than in accordance with applicable building codes;
4. failure to maintain the Heater or to operate the Heater in accordance with the Manufacturer’s specifications;
5. operation of the Heater under fluctuating or excessive water pressure or in the event the Heater is supplied with non-potable water, for any duration;
6. improper installation and/or improper materials used by any installer and not relating to defects in parts or workmanship of Manufacturer;
7. moving the Heater from its original place of installation;
8. exposure to freezing conditions;
9. water quality issues such as corrosive water, hard water, and water contaminated with pollutants or additives;
10. not continuously supplying the unit with water aka “dry-firing”.

Should Owner wish to return the Heater to manufacturer for repair or replacement under this warranty, Owner must first secure written authorization from Manufacturer. Owner shall demonstrate proof of purchase, including a purchase date, and shall be responsible for all removal and transportation costs. If Owner cannot demonstrate a purchase date this warranty shall be limited to the period beginning from the date of manufacture stamped on the Heater. Manufacturer reserves the right to deny warranty coverage upon Manufacturer’s examination of the Heater. This warranty is restricted to the Owner and cannot be assigned.

Some States and Provinces do not allow the exclusion or limitation of certain warranties. In such cases, the limitations set forth herein may not apply to the Owner. In such cases this warranty shall be limited to the shortest period and lowest damage amounts allowed by law. This warranty gives you specific legal rights and you may also have other rights which vary from State to State or Province to Province.

Owner shall be responsible for all labor and other charges incurred in the removal or repair of the Heater in the field. Please also note that the Heater must be installed in such a manner that if any leak does occur, the flow of water from any leak will not damage the area in which it is installed.